



PRESS INFORMATION

February 2021



1. INTRODUCTION	P.3
2. PRODUCT CONCEPT	P.4
3. ENGINE DESIGN	P.9
4. SUZUKI INTELLIGENT RIDE SYSTEM (S.I.R.S.)	P.25
5. CHASSIS DESIGN	P.40
6. STYLING DESIGN	P.49
7. ELECTRIC EQUIPMENT DESIGN	P.53
8. GENUINE ACCESSORIES	P.57
9. COLOR LINEUP	P.60
10. SPECIFICATIONS	P.61



When launched in 1999, the first generation Hayabusa shocked the motorcycle world by delivering a whole new level of speed, power and overall performance. It instantly gained the title of the world's fastest production motorcycle and gave birth to the ultimate sport bike category. Even though the industry's adoption of a self-imposed limit soon put an end to the era of top speed wars, the Hayabusa's outstanding performance across all metrics combined with its nimble handling and eye-catching appearance to keep it in the category's number-one position for the past two decades.

The original Hayabusa was much more than the sum of its parts. The abundant power its engine produced offered a wider range of gear selection options for any given speed, and this ultimately delivered a more controllable and pleasurable ride. Aerodynamic styling that instilled the Hayabusa with one of the lowest drag coefficients achieved on a production bike not only contributed to controllability, stability and rider comfort, its striking new design helped realize the Hayabusa's iconic presence. Sales of the first generation exceeded 115,000 units.

A full model change in 2008 retained all the hallmark features of the original Hayabusa, while increasing engine displacement and introducing new features that included a bold new body design. Further enhancement of performance in 2013 upgraded the front brakes and introduced an Anti-locking Brake System (ABS). These new features helped sell another 74,100 units over the life of the second generation, bringing total sales of the Hayabusa to more than 189,100 units.

Suzuki's team of engineers and designers have been working tirelessly since to refine countless aspects of the bike's performance to create an entirely new generation that is poised to further up the overall balance of performance and carry a new generation of Hayabusa riders into the future. The third generation Hayabusa leverages the latest technological innovations to provide greater control and comfort, and ultimately to assist riders in gaining confidence as they enjoy outings on the "Ultimate Sport Bike".



Left: The new Hayabusa
Middle: The second generation Hayabusa
Right: The first generation Hayabusa

The HAYABUSA product concept is;

“Ultimate Sport”

(Upping the ante with yet greater refinement, dignity and ultimate riding pleasure.)

The new-generation Hayabusa was developed not only to achieve an even higher overall balance of ultimate performance and comply with the stringent Euro 5 emissions standards, but also to capture the hearts of both devoted followers and all who lay eyes on the stunning beauty and sharper, tauter form of its bold new design.

Since its original launch in 1999, the Hayabusa has continued to provide riders with greater horsepower and torque than any other sport bike at engine speeds up to 6,000 rpm. The new Hayabusa proudly carries on this legacy as the ultimate sport bike, delivering even smoother torque and more power through the low to mid range, making it even faster and more controllable on the whole. An advanced new collection of intelligent electronic controls lets riders choose how the bike will respond and perform in various situations. This promotes greater rider confidence by helping even those who are less experienced learn how best to take advantage of what the Hayabusa has to offer. It also provides a number of additional comfort convenience features that bring greater pleasure to riding and pride to ownership.

The development team was fully committed to preserving all that made the Hayabusa a legend, while upping the ante in creating a new generation that is poised to carry riders into the future. The result faithfully reflects Suzuki’s ongoing commitment to fine craftsmanship and to sweating every detail to get them right.

2. PRODUCT CONCEPT

DESIGN CONCEPT

The design concept for the new Hayabusa's styling is "The Refined Beast". The goal was to visually express the intelligence embodied in the electronic control systems that enhance and advance the riding experience, and skillfully marry that with bold styling befitting a magnificent beast whose stance screams of power, performance, poise and keen perceptive abilities. The result is a due tribute to the Japanese peregrine falcon from which the Hayabusa takes its name.

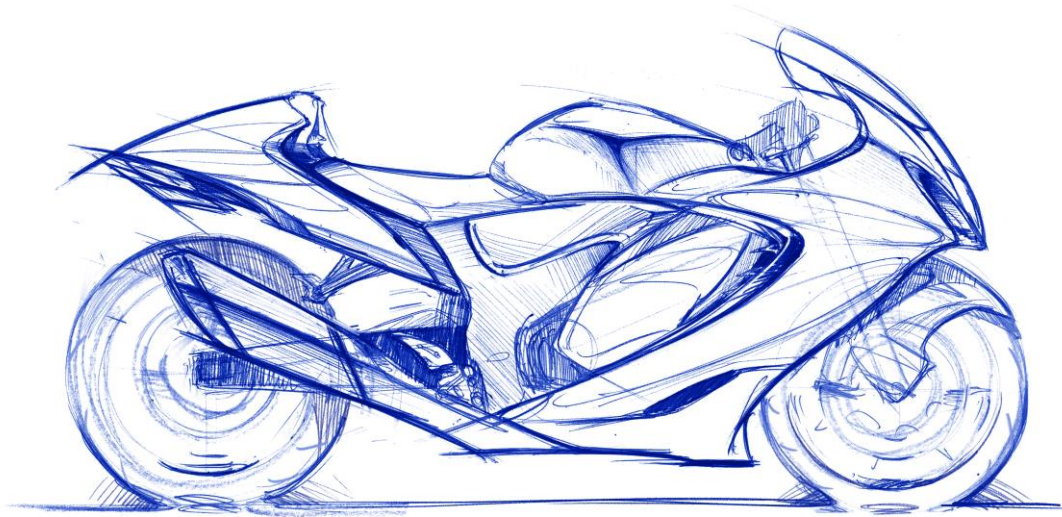

Image sketch

2. PRODUCT CONCEPT

Design Features

- Styling conveys a modern image of advanced performance and new features, all while faithfully inheriting the wind-cutting silhouette and overall look for which the Hayabusa is famous.
- An aggressive stance conveyed by its mass-forward impression, upswept tail, bold new rear combination lights, and the straight, upswept line from the exhaust pipe through the muffler.
- A modern, luxurious look as expressed in its sharper lines and fine attention to detail, the intricate shaping of its large, bold panel surfaces, the sharp, aerodynamic look of its attractive new mirror design, and the new 7-spoke wheel design.
- A face with a fresh new countenance as expressed through its tighter, bolder new headlight design and innovative position lights with integrated turn signals.
- The strategic application of color that creates a visual expression of the Hayabusa's great potential. This includes the trio of two-tone body colors. The unique theme for each of the available schemes also uses the secondary color to accentuate the sense of aerodynamic performance. Other examples include the chrome-plated V-shaped moldings on side cowlings that convey power and speed, new English and Japanese logos that heighten the image of speed and sophistication, and V-shaped accents inspired by the falcon's hackles on the black cladding below the fuel tank, air intakes and footpegs.

2. PRODUCT CONCEPT

KEY PRODUCT FEATURES

Engine features:

- Inherits the Hayabusa's legendary high-performance 1,340cm³ liquid-cooled inline-four engine, while implementing refinements to further improve efficiency and durability. **UPDATE**
- New exclusively designed exhaust system contributes to improved low- to mid-range power and torque output, and also to satisfying Euro 5 emissions standards. **UPDATE**
- Improved engine characteristics result in smoother, more consistently powerful output through the low- to mid-range engine speeds most commonly used in daily riding. **UPDATE**

Chassis features:

- Light, strong twin-spar aluminum alloy frame and swingarm constructed using castings and extrusions combine top performance with tried and proven reliability.
- Wind-cutting aerodynamic design features one of the best drag coefficients achieved by any motorcycle, excellent lift characteristics and wind protection. In addition to contributing to high-speed stability and controllability, this makes the ride more comfortable and less tiring. **UPDATE**
- Handling characteristics achieve a fine balance of confidence-inspiring stability at high speeds and nimble handling with reassuring controllability at low speeds. **UPDATE**
- Internal settings for the fully adjustable 43mm outer diameter KYB inverted front forks and KYB rear suspension changed to better absorb shock and realize even great straight-line stability. **UPDATE**
- 4-piston Brembo Stylema® front brake calipers paired with 320mm outer diameter discs improve braking efficiency. **NEW**
- New exclusively designed Bridgestone tires provide better grip. **NEW**
- New 7-spoke wheel design improves grip feel. **NEW**
- 50:50 front-rear weight distribution. **UPDATE**
- Handlebars mounted 12mm closer to the rider vastly improve comfort, reduce fatigue and also enhance handling control when enjoying a sporty ride. **UPDATE**

2. PRODUCT CONCEPT

Advanced electronic (controllability) features:

Suzuki Intelligent Ride System (S.I.R.S.) **NEW**

- Suzuki Drive Mode Selector Alpha (SDMS-a) featuring a selection of 3 factory preset and 3 user definable modes. **NEW**
 - Motion Track Traction Control System (10 modes + OFF) **NEW**
 - Power Mode Selector (3 modes) **UPDATE**
 - Bi-directional Quick Shift System (2 modes + OFF) **NEW**
 - Anti-lift Control System (10 modes + OFF) **NEW**
 - Engine Brake Control System (3 modes + OFF) **NEW**
- Active Speed Limiter **NEW**
- Launch Control System (3 modes) **NEW**
- Emergency Stop Signal **NEW**
- Suzuki Easy Start System **NEW**
- Low RPM Assist **NEW**
- Cruise Control System **NEW**
- Combined Brake System **NEW**
- Motion Track Brake System **NEW**
- Slope Dependent Control System **NEW**
- Hill Hold Control System **NEW**

Electric Equipment Features

- Instrument cluster with a modern new look and enhanced functionality. This includes the introduction of a new TFT LCD panel between the large analog tachometer and speedometer that features an Active Data display offering a real-time view of the bike's running status. **NEW**
- Vertically stacked Multi-LED headlight creates a sharp new look with its large, bold styling and eye-pleasing presence. **NEW**
- Position lights with integrated turn signals neatly flanking the outer edges of the large SRAD air intakes are a first on a Suzuki motorcycle. **NEW**
- LED rear combination lights create a sharp accent running horizontally across the bottom of the tail section. **NEW**
- Ergonomic handlebar switch design features operating ease and efficiency. **NEW**

Introduction

Development of a further refined engine for the new Hayabusa centered on the following design targets.

1. Improve durability and longevity.
2. Achieve greater power and torque with smoother delivery throughout the low to mid speed range.
3. Introduce the latest electronic control systems that help build rider confidence and provide an even more pleasant riding experience.
4. Satisfy Euro 5 emissions standards without sacrificing top speed.

As the fruit of Suzuki's earnest and continuous efforts to develop and refine its engine technologies, the Hayabusa engine has long been popular for its accessibility, serviceability, adaptability and durability. Suzuki refused to make any compromises in challenging to not sacrifice any of these attributes while pursuing the above-listed targets.

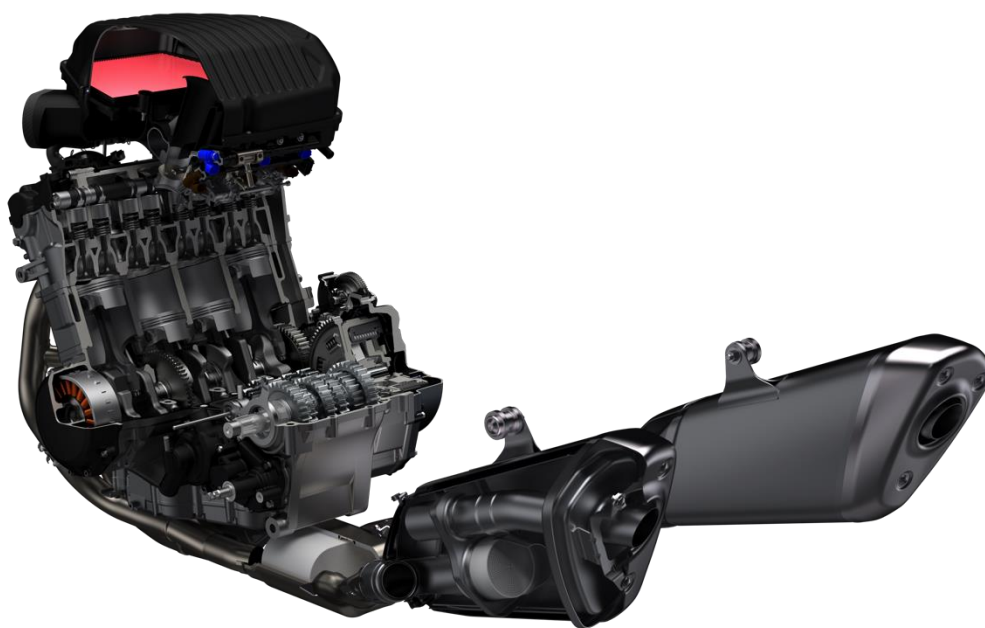

Engine cutaway

Refinements implemented throughout the Hayabusa's legendary 1,340cm³ liquid-cooled inline-four engine further improve efficiency and durability, achieve an overall better balance of performance and satisfy Euro 5 emissions standards.

The result is better torque and power delivery with a more linear power curve in the low to mid speed range, which is where the rider ultimately spends much of their time in daily use or when touring. As such, the new Hayabusa proudly carries on the legacy of the previous generations by providing riders with greater output and smoother torque than any other sport bike at engine speeds up to 6,000 rpm.

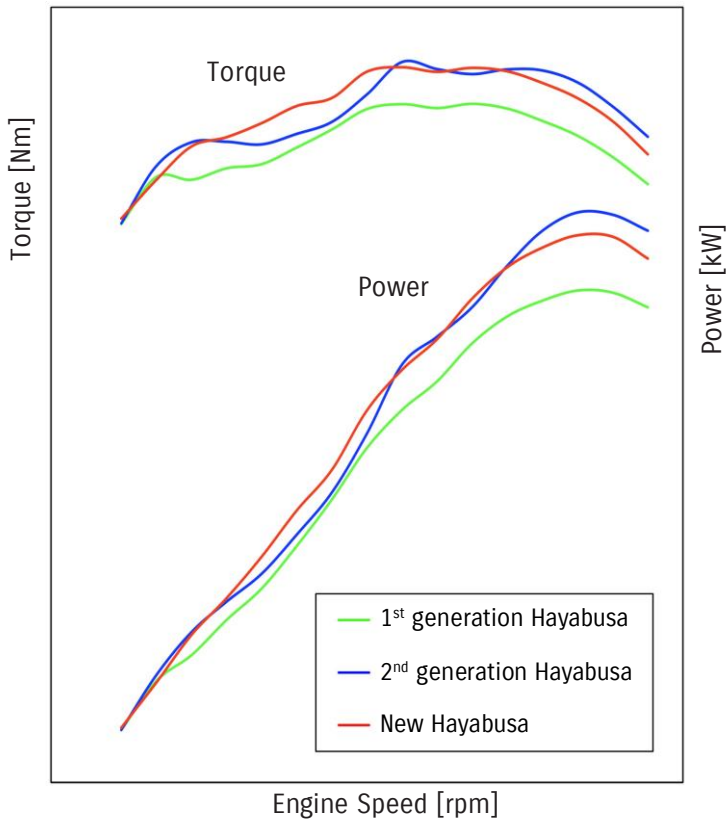

While peak output is marginally lower than on the second-generation model, the new Hayabusa's broad power curve produces equivalent or greater overall output when measuring the total value across the range of low through high engine speeds.

Total torque area across the range

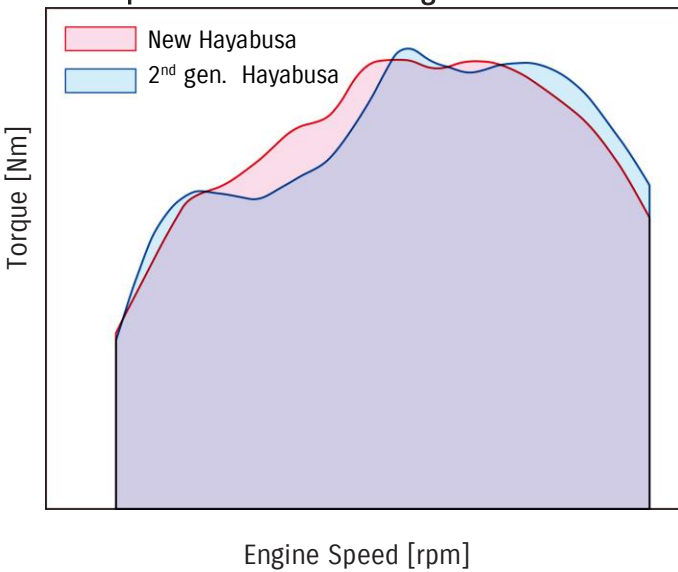

The Hayabusa adopts a variety of the latest electronic control systems that provide finer control over the engine's output characteristics. This enables riders to find settings that are more reassuring and best suited to the riding conditions of the moment. The result is a stronger sense of communicating directly with the bike's heart and brain as the rider explores the potential of the Ultimate Sport Bike.

Overall performance is such that the new Hayabusa is capable of outpacing its predecessors in most daily situations. Though maximum output falls between that of the original and second generations, refinements to the engine and introduction of the latest electronic control technologies give the new Hayabusa the edge at engine speeds the rider uses most of the time. The quarter-mile time is the same as for the second generation and the new model easily reaches its nominal factory-limited top speed of 299km/h.



4-stroke, 4-cylinder, liquid-cooled, DOHC, 1,340cm³ engine

3. ENGINE DESIGN

Hayabusa

	1 st generation Hayabusa	2 nd generation Hayabusa	New Hayabusa
Displacement	1,298cm ³	1,340cm ³	
Bore x Stroke	81.0mm x 63.0mm	81.0mm x 65.0mm	
Compression ratio	11.0:1	12.5:1	
Maximum power	129kW (175PS)/9,800rpm	145kW (197PS)/9,500rpm	140kW (190PS)/9,700rpm
Maximum torque	138N-m/7,000rpm	155N-m/7,200rpm	150N-m/7,000rpm
0-200m time (seconds)*	7.1	6.9	6.8
0-100km/h time (seconds)*	3.3	3.4	3.2
Top speed (km/h)	299	299	299
Emissions compliance	-	Euro 3	Euro 5
Fuel consumption (WMTC) (km/l)	-	17.6	14.9

* Suzuki's internal test results. Figures may vary by rider's skill or riding conditions.

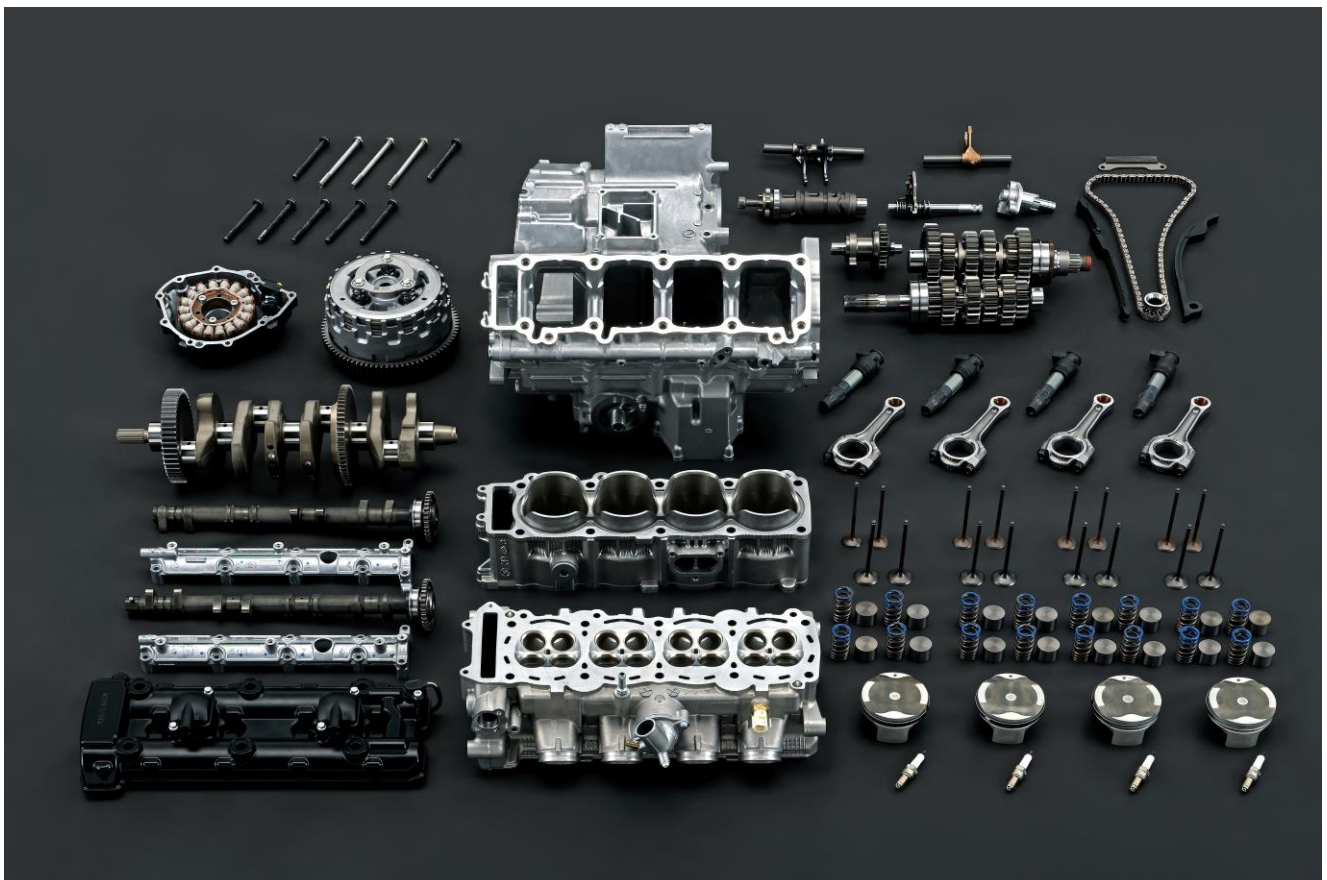



Parts redesigned for the new Hayabusa are shown in yellow.

- >Intake and exhaust cam system: Revised cam profiles to reduce valve lift overlap.
- >Valve spring: Spring load increased in conjunction with the increased exhaust valve lift.
- >Pistons: New shape, weight reduced and conical-machined wrist pin holes adopted.
- >Piston pins: Shorter length to reduce weight.
- >Connecting rods: Weight reduced and rigidity increased.
- >Crankshaft: Revised oil passages.
- >Crankcase: Journal bolt tightening method.
- >Magneto: Engine starting improved by moving keyway 6 degrees.
- >Pushrod: Length adjusted.
- >Transmission retainer: Newly adopted on the new Hayabusa to improve serviceability.
- >Right and left counter bearings: Lengthened needle bearing rollers improve durability.
- >Gearshift stopper: For setting shift feeling in conjunction with the adoption of the Bi-directional Quick Shift System.
- >Gearshift cam plate: New design to accommodate the adoption of the Bi-directional Quick Shift System
- >Gearshift cam: New design to accommodate the adoption of the Bi-directional Quick Shift System.
- >Clutch assembly : Adopted a new assist & slipper clutch
- >Countershaft: Length of right end revised in conjunction with the adoption of the A&S clutch.
- >Transmission gears: Bearing width revised to improve shift feeling.
- >Cam chain tensioner: redesigned to minimize chain runout.

Improved durability **UPDATE**

Although the Hayabusa engine is already renowned for its reliability, durability and longevity, the development team was committed to further evolving it to a higher new level. The team reviewed every detail to reduce sources of internal vibration and strengthen key components as they worked tirelessly to achieve this goal.

Borrowing from technology used on the GSX-R1000, changes to the crankshaft oil passages deliver oil more efficiently to the connecting rods. This achieves a 54% improvement in flow and pressure at the crank without making any changes to the oil pump, and the overall result is improved engine lubrication.



Previous oil passages

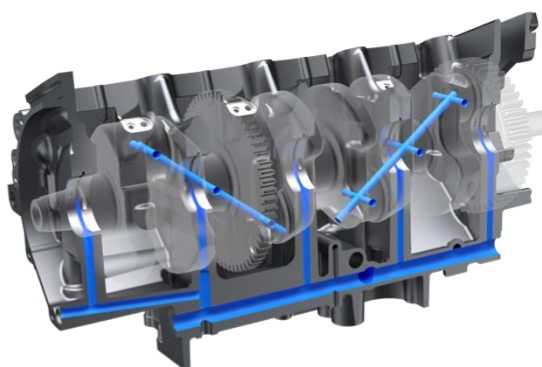

New oil passages

New connecting rods that further reduce the width of the small end (top) in comparison to the big end (bottom) cut the weight of each rod by 3 grams. At the same time, the volume of the arm area at both the big and small ends is increased to enhance rigidity. Furthermore, a new piston design takes 26 grams off the weight of each piston. Reducing the weight of these moving parts lessens internal vibration, which in turn contributes to greater engine durability.



New Piston



New connecting rods

Other changes to enhance durability include extending the roller length of the transmission shaft needle bearings from 11 mm to 13 mm. Angle control tightening replaces torque control tightening for the engine case bolts to narrow preload variation and thereby prevent potential deformation of the journal bolts over time. Attention to detail extends to changing from cut threads to rolled threads for the holes in the upper crankcase cover. Rolled threads are harder and less prone to cracking from wear, so help maximize holding strength for the journal bolts that support the crank.

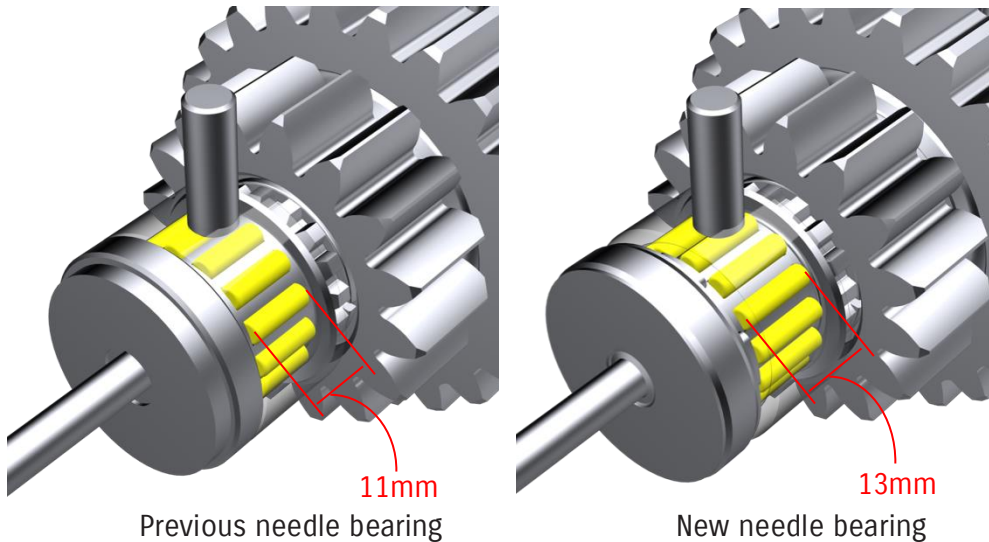

Performance improvements

Exhaust system **UPDATE**

A new pipe connecting cylinders #1 and #4 helps deliver more robust power and torque at low-to-mid-range speeds. (Cylinders #2 and #3 were connected on the previous design.) The single-stage catalytic converter of the previous generation is replaced by a new two-stage system that positions an elliptical (“racetrack-shaped”) converter in the collector followed by a cylindrical one in each of the right and left mufflers. This combines with adding a second O₂ sensor to help satisfy Euro 5 emission standards.

Changes to the cam profiles, application of the latest CAE analytical tools, and effective use of the area behind the catalytic converter in the exhaust pipes made it possible to reduce the capacity of the mufflers by 1.98 liters while still clearing the Euro 5 emissions standards. In addition, the change to single pipes at the back end and the adoption of a simpler muffler structure takes 2,054 grams off the weight of the exhaust system. Additionally, the mufflers adopt a 2-compartment design inside that replaces the previous 3-compartment design. This change simplifies the internal structure, reducing the weight of the mufflers and allowing for greater freedom to create a more attractive exterior design.



Previous exhaust system

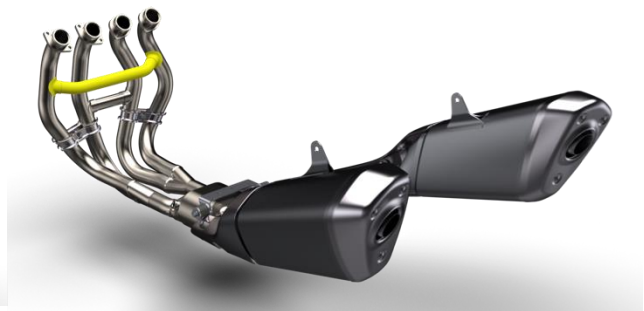

New exhaust system



Previous catalytic converter



New catalytic converter

As an added benefit, the exhaust note for this new system was tuned and optimized using Suzuki's own Exhaust Sound Quality Evaluation Program. The new Hayabusa's exhaust sound does not disturb the rider while on the road, but does produce a powerful note the instant the engine is started. The Exhaust Sound Quality Evaluation Program makes quantitative evaluation possible. This in turn enabled the development team to achieve thickness and distinctiveness that surpasses the previous model.

Exhaust sound quality evaluation results

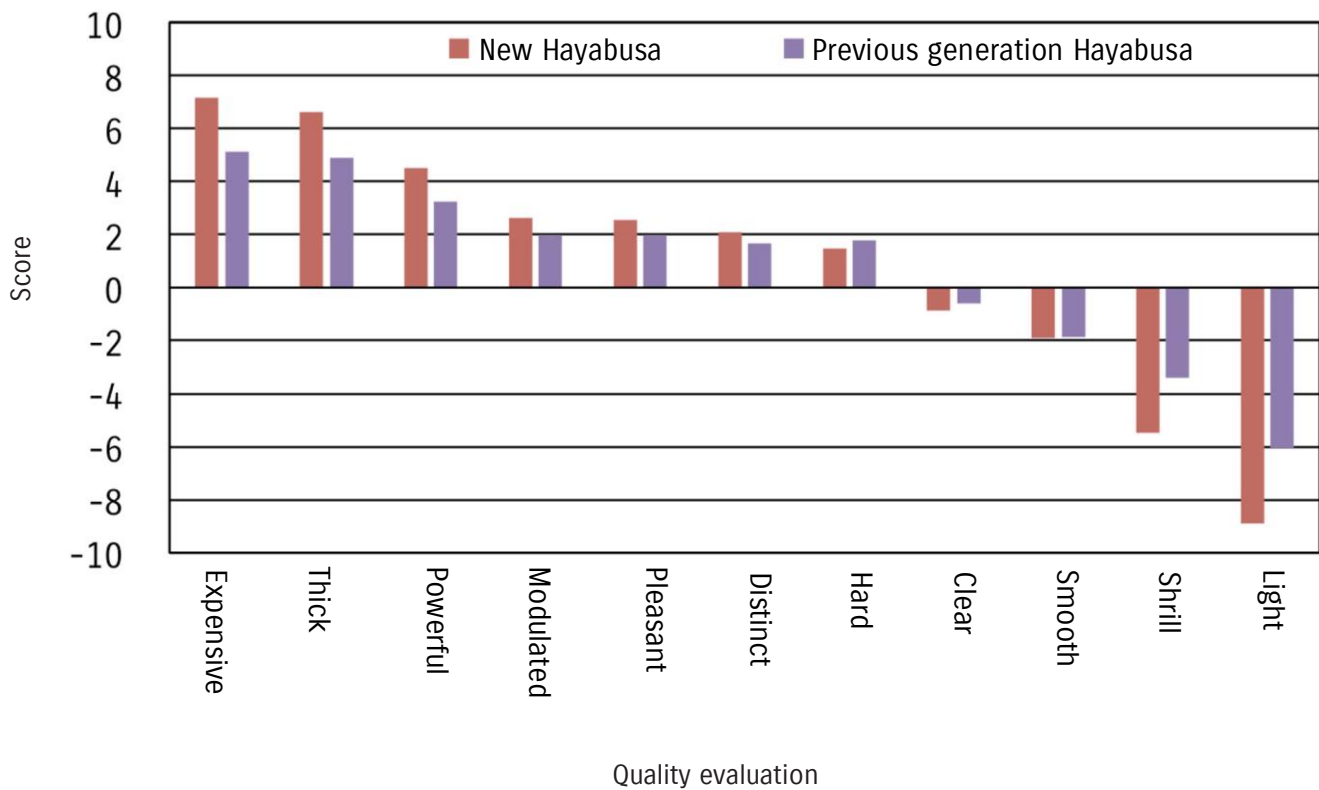

Twin Swirl Combustion Chamber (TSCC) UPDATE

Suzuki's combustion chamber design promotes faster and more efficient burning of the fuel-air mixture. It employs a four-valve design with each pair of intake and exhaust valves positioned in adjoining semi-hemispherical depressions. During the intake stroke, these depressions channel the incoming air-fuel mixture into two controlled high-speed swirls. Squish areas in the front and back of the chamber accelerate the speed of the swirls, igniting the mixture more quickly and effectively. After closely examining and analyzing the flow of air as it entered the chamber to further leverage the inherent strengths of the TSCC design, the combustion chamber around the intake valve was machined further on the new Hayabusa engine. This expands the valve curtain area and improves the flow coefficient by 5% as the valve begins to open and reaches 5mm in lift height. As a result, this change increases combustion efficiency and helps satisfy Euro 5 emissions standards.



Previous TSCC



New TSCC

Flow coefficient comparison

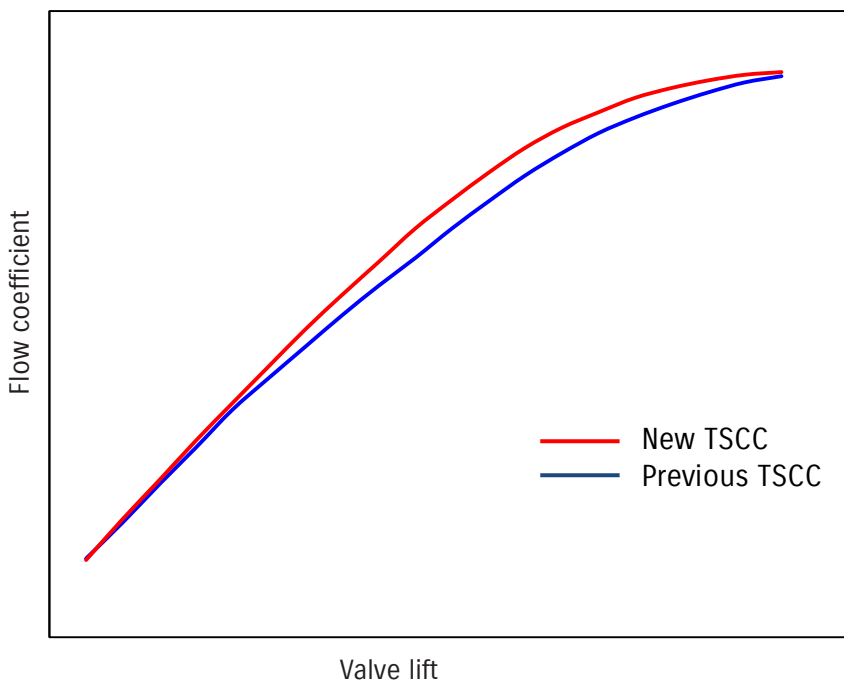

Pistons **NEW**

While the Hayabusa continues to use forged pistons with chrome nitride PVD-coated oil control rings, it adopts a new piston shape that is optimized to match the new TSCC shape. The changes to the crankshaft oil passages increases the flow of the piston-cooling oil jets, which in turn cool the pistons more efficiently. Advances in CAE analysis made it possible to remove enough material to reduce the weight of each piston by 26 grams. This reduces internal vibration, which in turn contributes to enhanced durability. In addition, conical machining inside the wrist pin hole transfers load and mitigates stress transferred to the piston. As a result, it too contributes to improving durability.

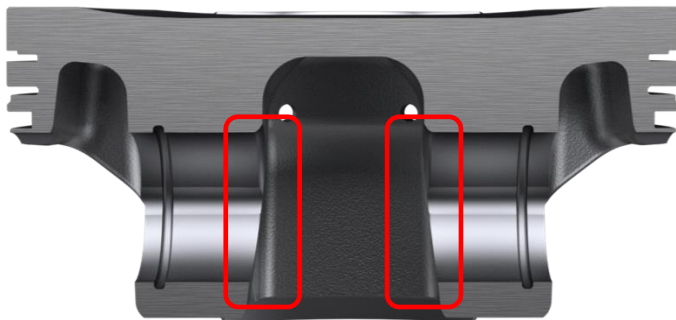

Piston conical machining

Suzuki Side Feed Injector (S-SFI) **NEW**

The Hayabusa adopts a new dual injector design that places the secondary injector at an angle on the side of the intake funnel. Its spray strikes a reflecting plate in the funnel and creates a fine mist that enters the combustion chamber. The result is a 2% increase in power and torque output in low- to mid-range. The injectors themselves adopt a new design that sprays a finer mist. This improves fuel mixture loading efficiency and further contributes to boosting output.

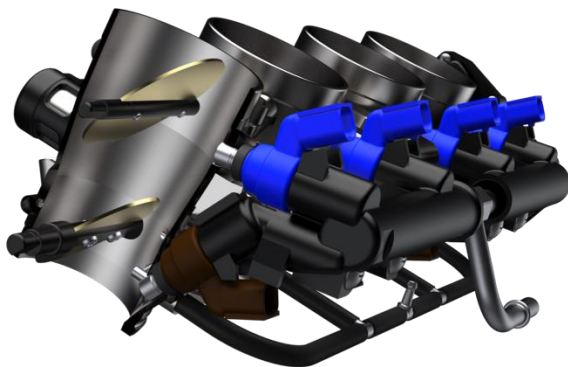

Previous throttle body and injectors

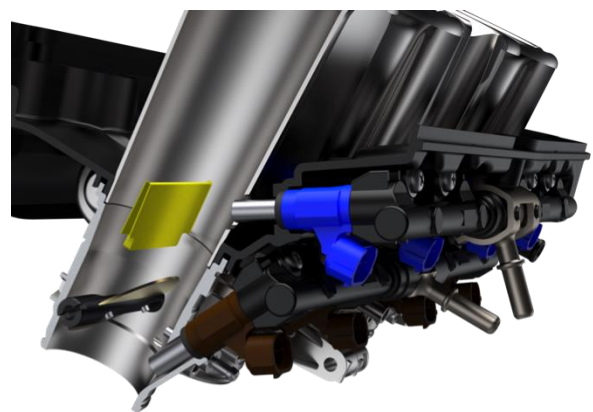

New S-SFI

Ride-by-Wire Electronic Throttle System **NEW**

In addition to making it possible to introduce the new Hayabusa's variety of electronic control systems because the ECM controls the action of the throttle body, Suzuki's electronic throttle control system provides light, natural response with linear control similar to that of conventional throttle operation. In conjunction with the introduction of this new throttle system, the size of the tapered throttle bodies changed from 44mm to 43mm and the overall intake pipe length, (including the intake pipe, throttle body and funnel), is extended by 12mm over the previous intake system. This contributes to producing greater power output at low- to mid-range engine speeds.



New throttle body

Air cleaner box **UPDATE**

Changes to the shape of the throttle bodies made it possible to increase the air cleaner box's capacity from 10.3 liters to 11.5 liters. The lid adopts a new corrugated shape that increases the box's structural rigidity. The resulting design improves intake sound quality, while also allowing for the elimination of the internal support posts.



Previous air cleaner box

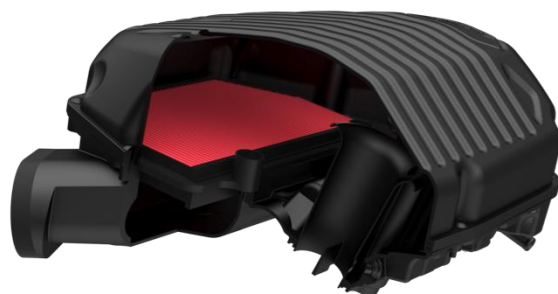

New air cleaner box

Suzuki Ram Air Direct (SRAD)

Flow analysis applied to the Suzuki Ram Air Direct (SRAD) intake ducts reduces pressure loss and increases the flow of pressurized air into the air cleaner. This results in achieving a finer balance between the design of the shape for the ducts and its contribution to output and engine characteristics. Additional benefits of this new design include its contribution to outstanding aerodynamic performance and producing a satisfying intake sound. **UPDATE**



Previous SRAD duct

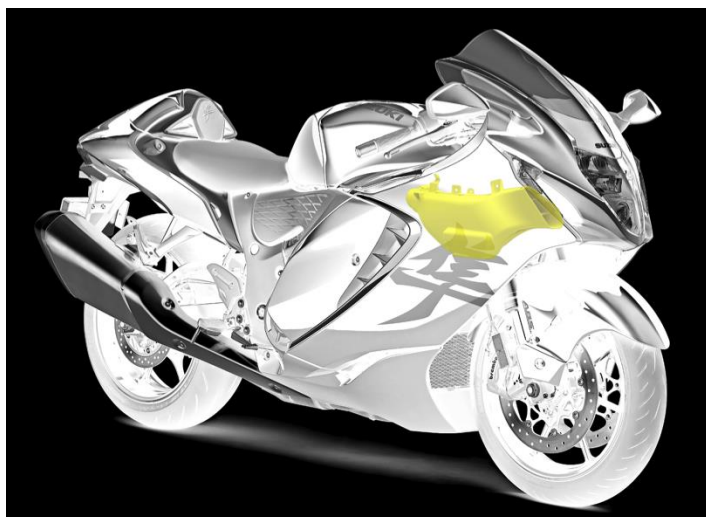
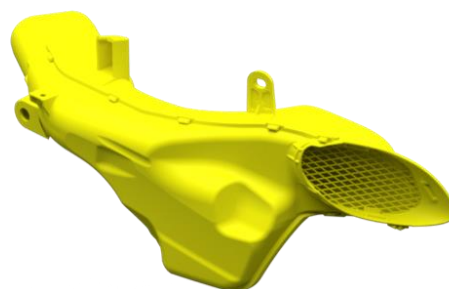

New SRAD duct

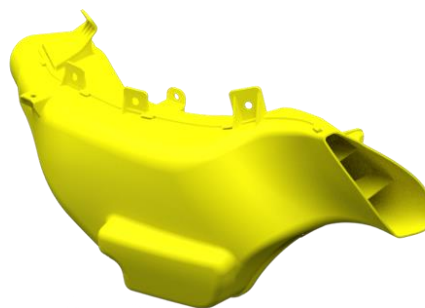

Additional features

- While the proven lightweight titanium valves are carried over from the previous generation, the new Hayabusa adopts a revised cam profile that reduces valve lift overlap to improve performance and controllability at the most commonly used low- and mid-range speeds. Improving emissions performance and reducing the action angle places added load on the slipper surface, so the width of the cam lobes was increased to achieve greater durability.

UPDATE

Cam profile

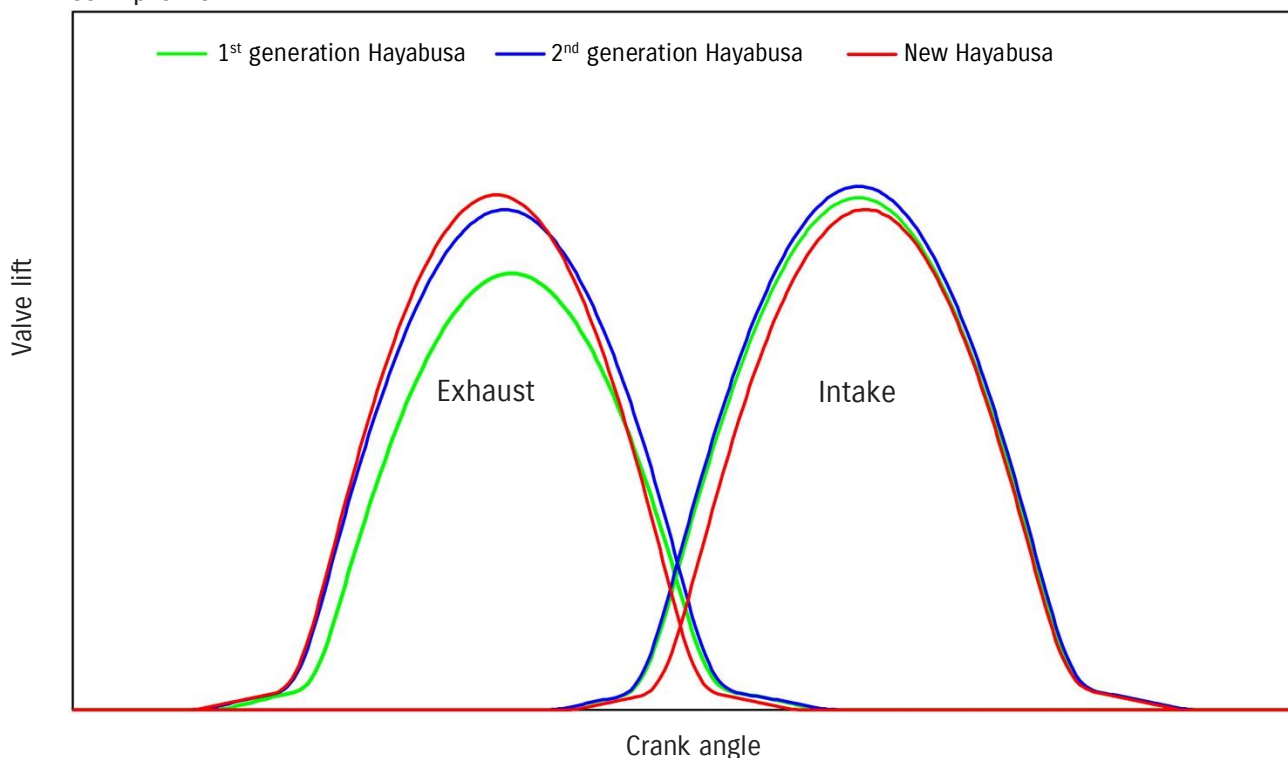

New cam shaft

- The cam chain tensioner was redesigned to minimize chain runout, and the addition of a teflon sheet on the slipper surface reduces mechanical loss. **UPDATE**

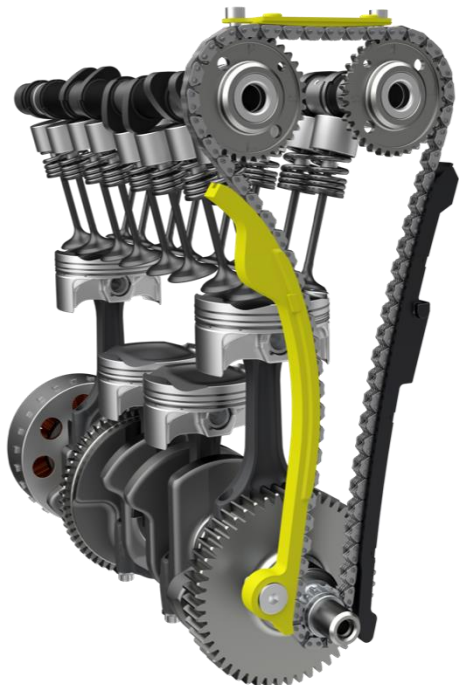

New cam chain tensioner

- Suzuki Clutch Assist System (SCAS) adopts a new assist & slipper clutch to smooth shifting and engine response during engine braking and corner entry. It also realizes a light touch to clutch lever operation despite the amount of torque being produced. **UPDATE**



New clutch

- Suzuki Composite Electrochemical Material (SCEM)-plated cylinders reduce friction and improve heat transfer and durability.

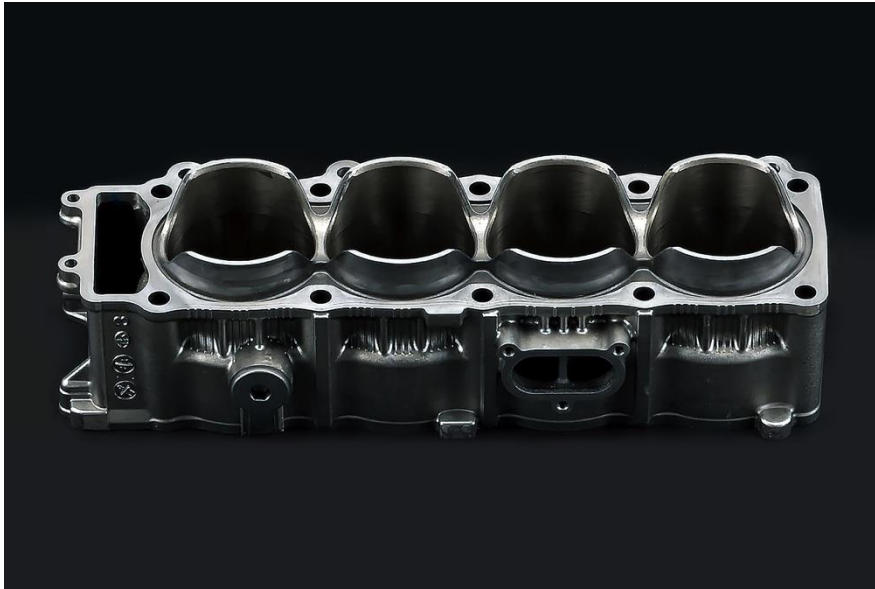

Cylinder

- Styling design changes reduce radiator air resistance and allow air to pass through more efficiently. This improves cooling efficiency. Reducing resistance by approximately 8% improves air flow at all speeds, while an increase of approximately 7% in the volume of air moved by the fan improves flow at low- to mid-range speeds. The result is an overall improvement in cooling efficiency. Coupled with a wider fan pitch and reduced fan cover size, these changes allow the fans to spin down when stopping in busy traffic. **UPDATE**



New radiator

Introduction

The Hayabusa adopts an advanced new version of the Suzuki Intelligent Ride System (S.I.R.S.), a robust collection of electronic systems designed to optimize performance characteristics to match the needs of the moment and make the Hayabusa more controllable and predictable. Riders can opt for settings that best suit riding conditions and varying road surfaces, as well as their level of confidence and experience. They can benefit from the feedback those settings offer and take advantage of it to further hone their riding skills and gain greater confidence as they enjoy the ultimate riding experience.

Countless hours of repeated track testing, analysis and revisions to the programming for each setting aimed to achieve optimal performance in every conceivable situation and to ensure the reliability of each system.

Suzuki Drive Mode Selector Alpha (SDMS- α) **NEW**

SDMS- α offers a choice between three factory presets, (A: Active, B: Basic, and C: Comfort), as well as three user-defined settings (U1, U2, U3). Each one of these selects the mode settings as a group for the Power Mode Selector, Motion Track Traction Control, Anti-lift Control, Engine Brake Control and Bi-directional Quick Shift systems. The rider uses switches on the left handlebar to change modes and settings, and the current settings are displayed on the TFT LCD panel located in the center of the instrument cluster, between the Hayabusa's large analog speedometer and tachometer.

Factory presets mode

	A (Active)	B (Basic)	C (Comfort)
Power Mode Selector	1	2	3
Motion Track Traction Control	1	5	10
Anti-lift Control	1	5	10
Engine Brake Control	OFF	OFF	OFF
Bi-directional Quick Shift	1	1	2

(1) Control over engine output characteristics

Power Mode Selector (PW) UPDATE

The rider can select between three different output characteristic modes. Mode 1 provides the sharpest throttle response, Mode 2 provides more linear power delivery with softer throttle response, and Mode 3 provides the softest throttle response and a more gentle power curve with reduced maximum output.

Power delivery image by mode

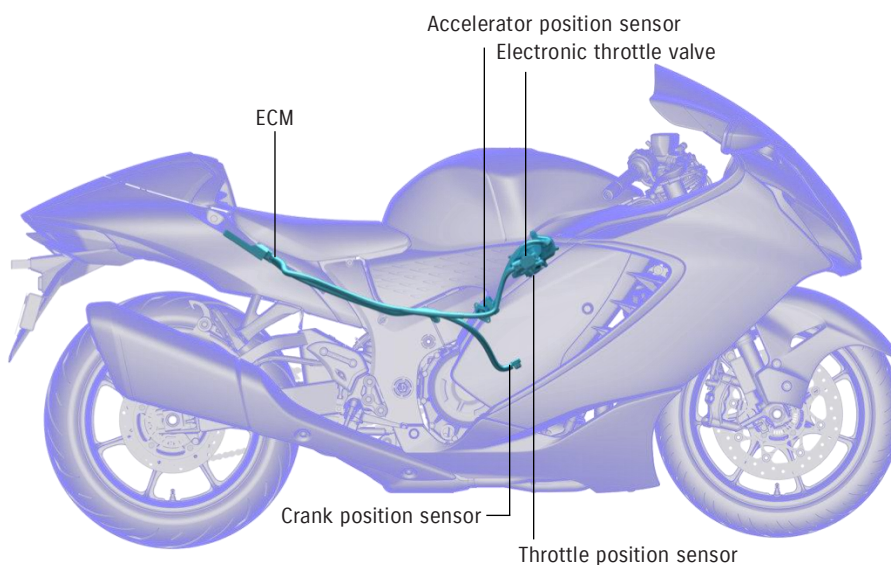
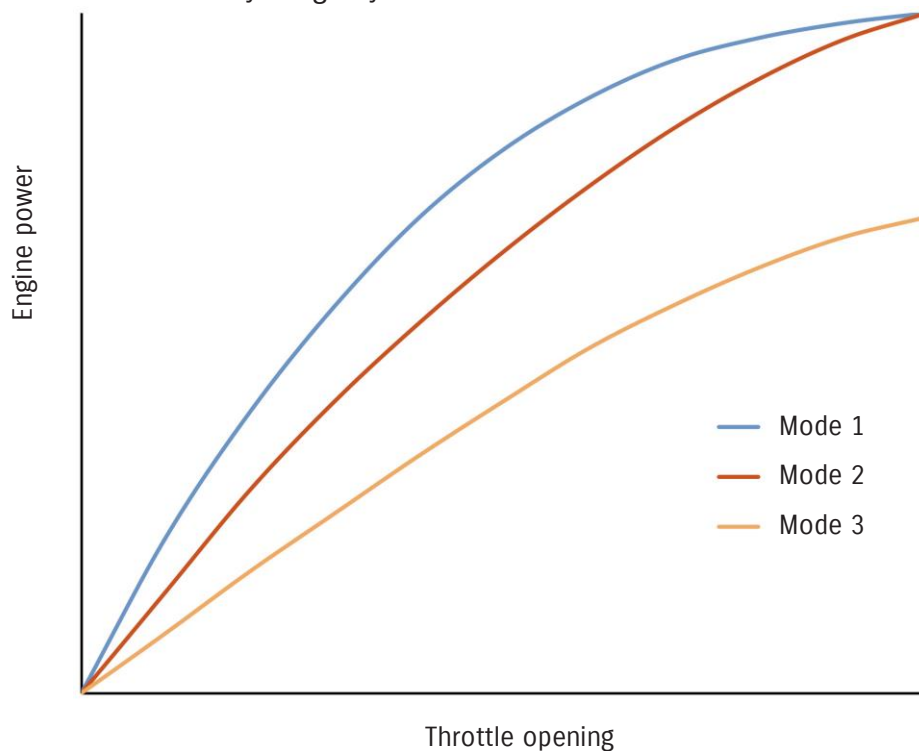

(2) Control over engine acceleration characteristics

Motion Track Traction Control System (TC) **NEW**

Designed to provide greater stability and enable the rider to control the Hayabusa with confidence in varying riding conditions while experiencing less stress or fatigue, this system features smooth control that does not interfere when enjoying a more aggressive, sporty ride. It offers 10 mode settings and can also be turned off. The higher number the mode, the faster the control takes effect and the more proactive the system is in limiting wheel spin. In addition to monitoring front and rear wheel speed, engine RPM (as calculated using data from the crank position sensor), throttle position and gear position, the system uses data from the inertial measurement unit (IMU) to constantly monitor the amount of lean angle as well. When the system determines an imminent loss of traction, the ECM controls output to the electronic throttle valve, ignition coil, spark plugs and fuel injectors to limit power and prevent slipping. This technology is adopted directly from the traction control system Suzuki developed for MotoGP racing. The TC indicator in the center of the instrument cluster flashes when the system is operating.

Overview diagram

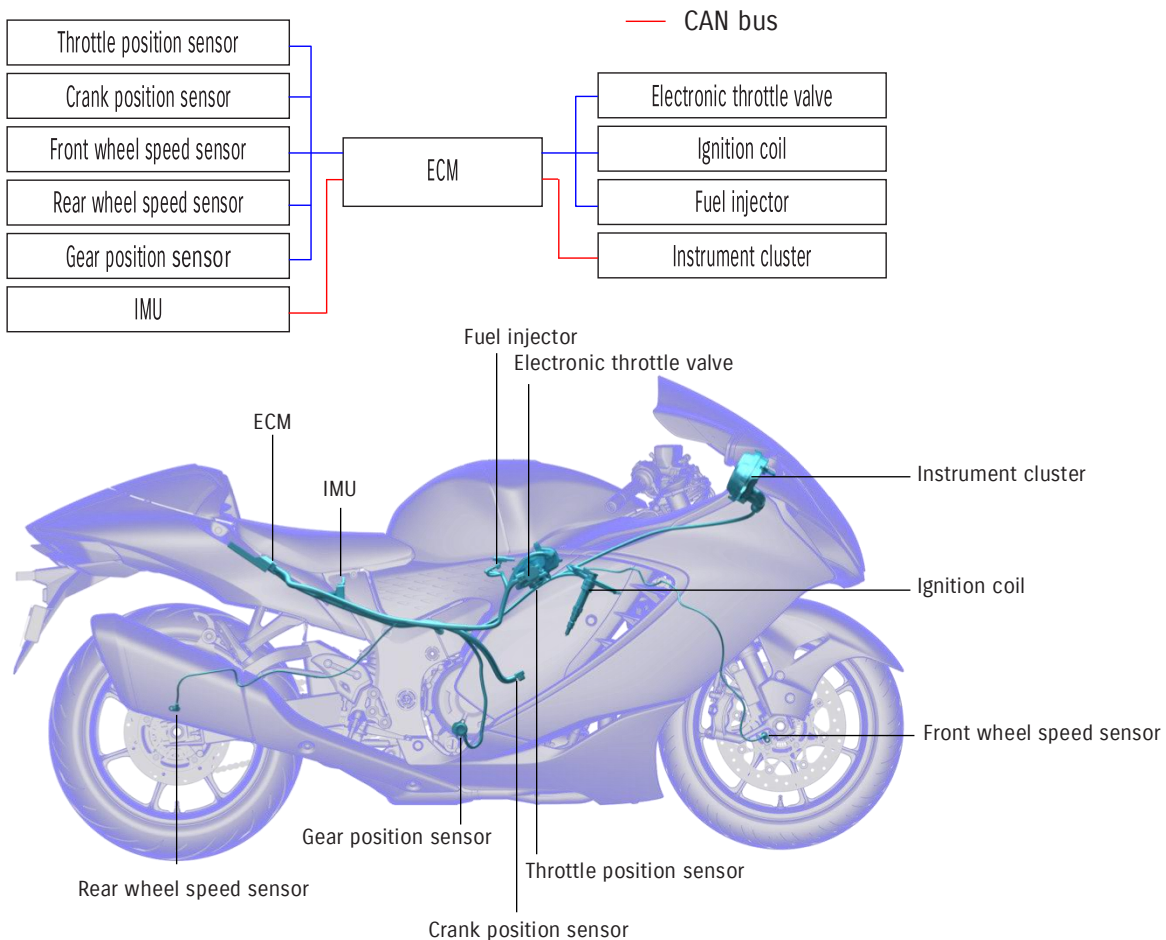

Note: The Motion Track Traction Control System is not a substitute for the rider's throttle control. It cannot prevent loss of traction due to excessive speed when the rider enters a turn and/or applies the brakes. Neither can it prevent the front wheel from losing grip.

Anti-lift Control System (LF) **NEW**

Adds reassurance to riders by helping prevent the front wheel from lifting off the ground when accelerating. The rider can choose from 10 modes, or turn the system off. The higher the setting, the greater the amount of control supplied. When in Mode 10, for example, it is virtually impossible to lift the front wheel, even with a passenger on the back and the throttle wide open.

In addition to monitoring engine RPM (as calculated using data from the crank position sensor), the Hayabusa's dual-core 32-bit ECM processes data input from the throttle position, gear position, clutch switch and front and rear wheel speed sensors, as well as the IMU, to determine the appropriate amount of output to deliver in response to operation of the electronic throttle control.

Overview diagram

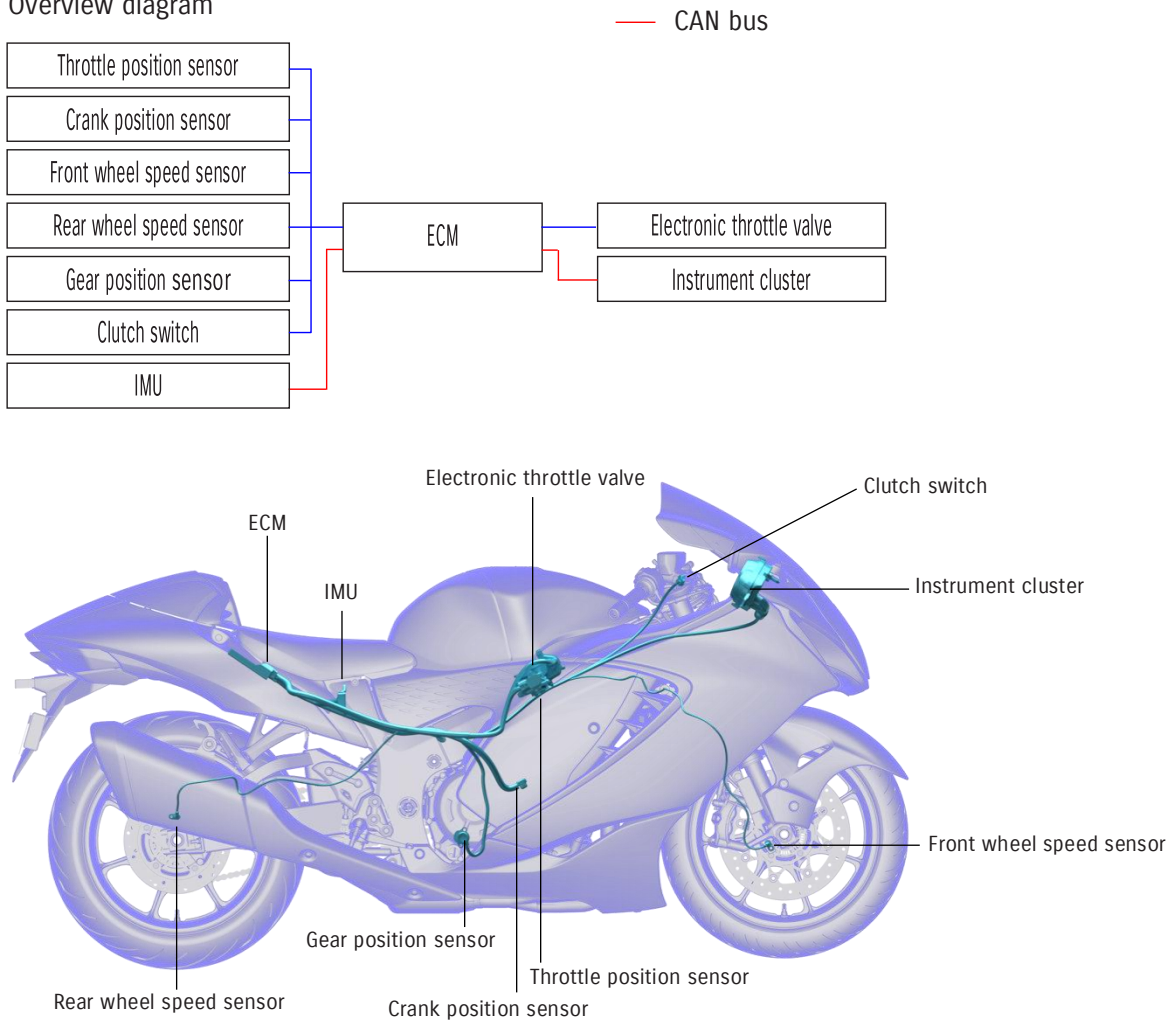

Launch Control System **NEW**

Helps ensure efficient launch and acceleration from a standing start. Launch Control for the Hayabusa offers 3 modes from which the rider can choose to match his or her level of experience or confidence. Mode 1 limits engine speed on launch to 4,000 rpm, Mode 2 operates at 6,000 rpm, and Mode 3 – the fastest mode – operates at 8,000 rpm.

Overview diagram

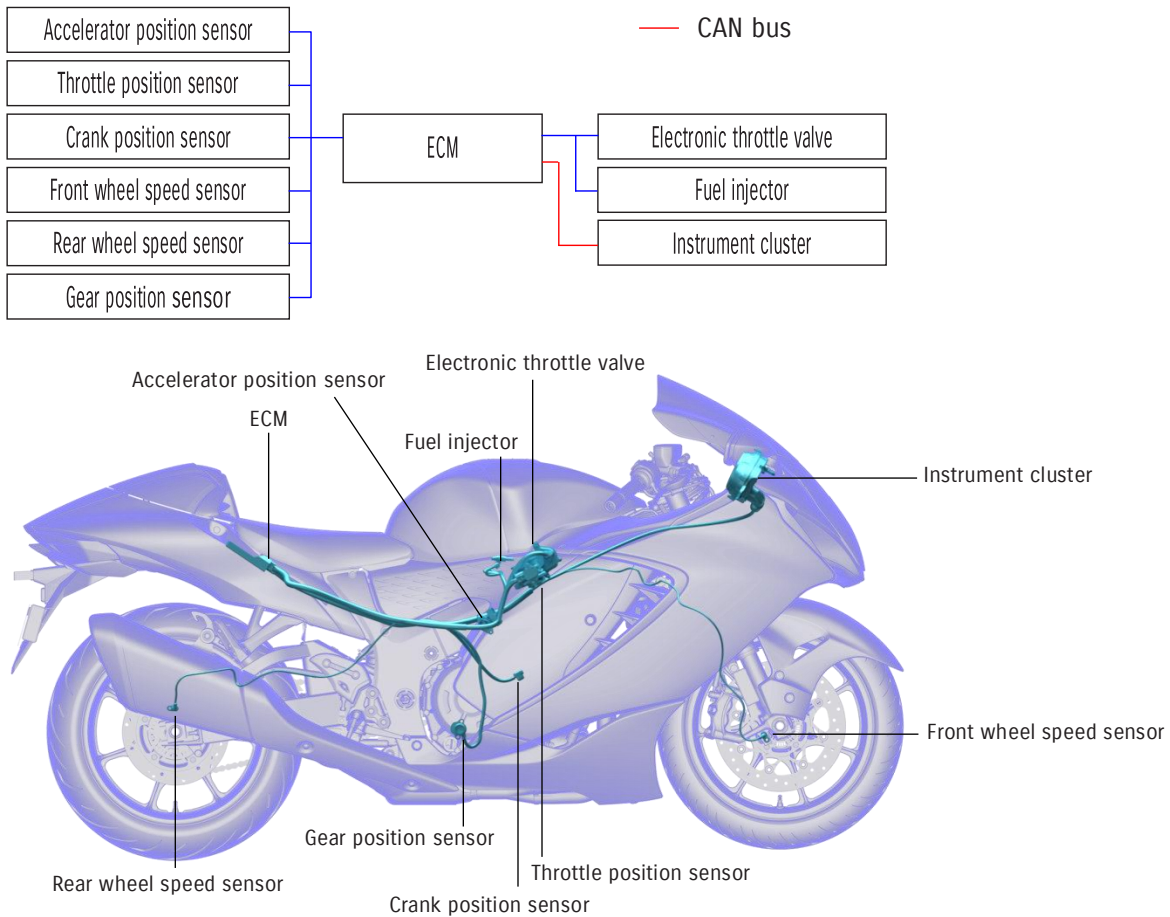

(3) Control over engine deceleration characteristics

Engine Brake Control System (EB) **NEW**

With three modes and an OFF setting, this system provides control over the effective strength of engine braking to match the rider's preference. The higher the setting, the more the system provides the rider with smoother, more controllable behavior by cancelling out the effect of engine braking to suppress rear tire sliding or skipping when decelerating after releasing the throttle grip or downshifting.

In addition to monitoring engine RPM (as calculated using data from the crank position sensor), the ECM processes data input from the accelerator position, gear position, clutch switch and front and rear wheel speed sensors to determine the appropriate amount of output to deliver to the electronic throttle, injectors and ignition coil.

Overview diagram

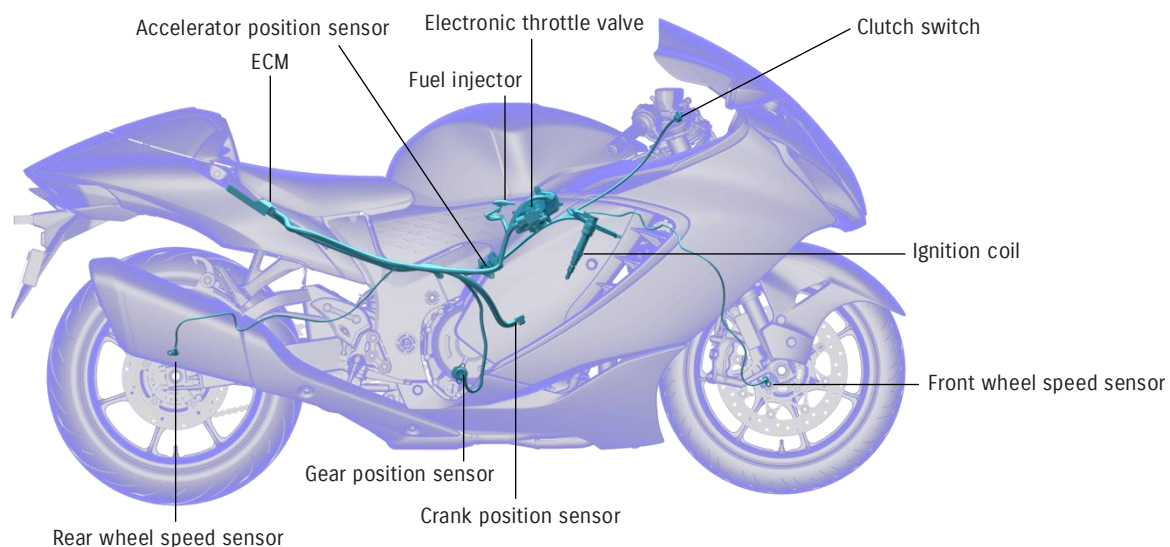
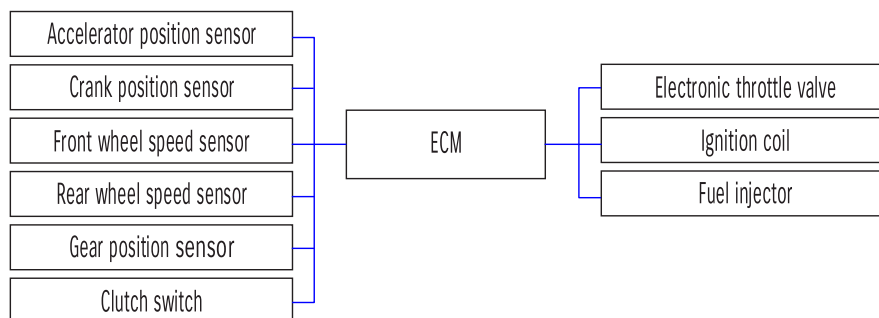

(4) Control over engine at steady speeds

Active Speed Limiter **NEW**

A first in the motorcycle industry, this highly practical system allows the rider to set a speed limit the bike will not exceed, eliminating worries about speeding or driving faster than intended. The rider can accelerate freely up to that speed and decelerate normally by backing off the throttle. The system can be temporarily overridden with one quick twist of the throttle, making it easy to accelerate beyond the set limit to pass other vehicles. It can be deactivated completely at the press of a button after releasing the throttle grip.

Overview diagram

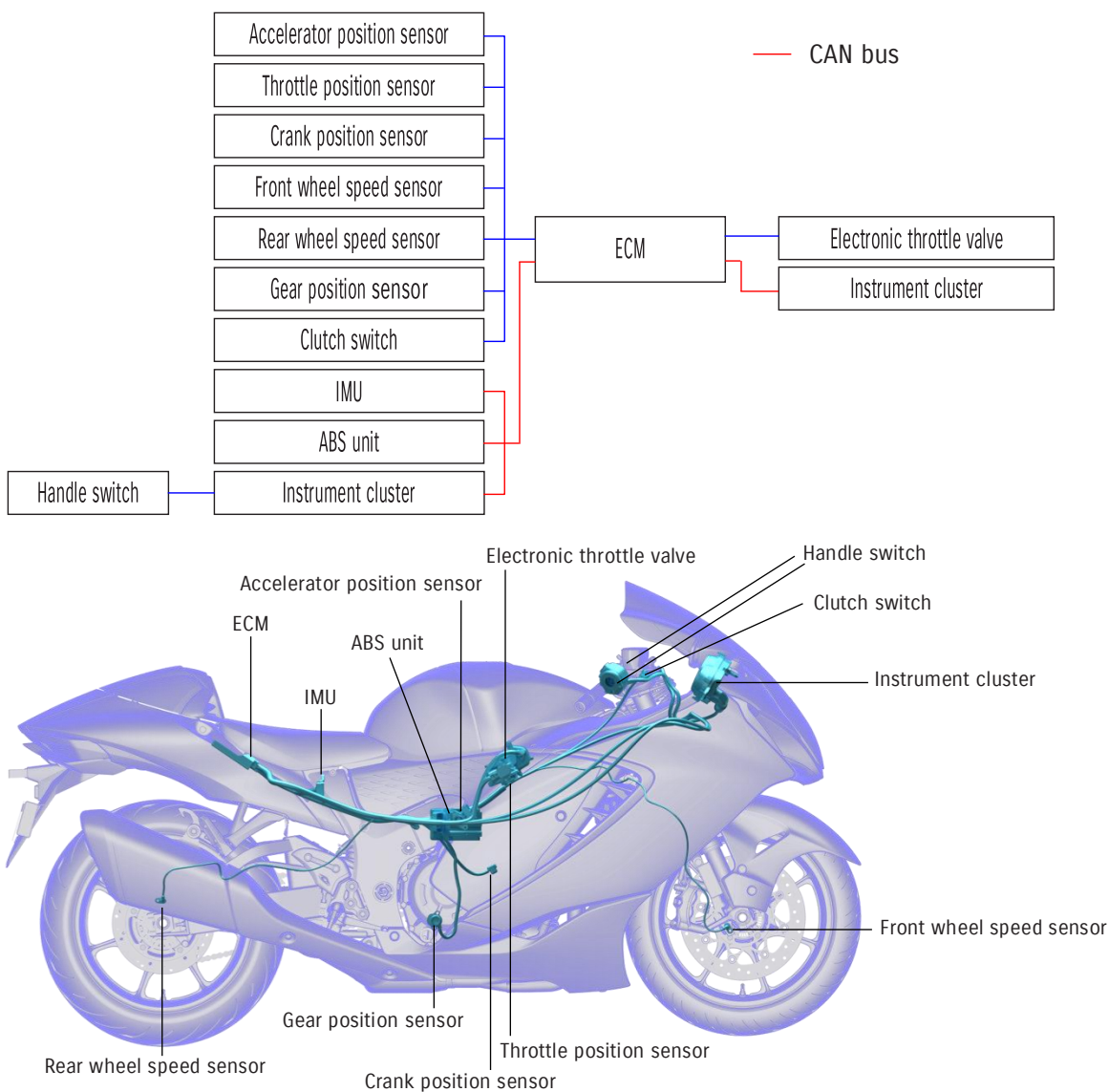

Cruise Control System **NEW**

A convenient feature when travelling at constant speed on highways, Cruise Control reduces fatigue on long rides by allowing the rider to maintain a set speed without operating the throttle. The setting appears on the LCD display and the speed can be easily adjusted upward or downward using the select switch (plus or minus) on the left handlebar. Cruise Control can be set from 31km/h to 200km/h while riding at 2,000 to 7,000 rpm in second gear or higher. The handy resume function re-engages the system and accelerates to the most recent speed setting after canceling.

Overview diagram

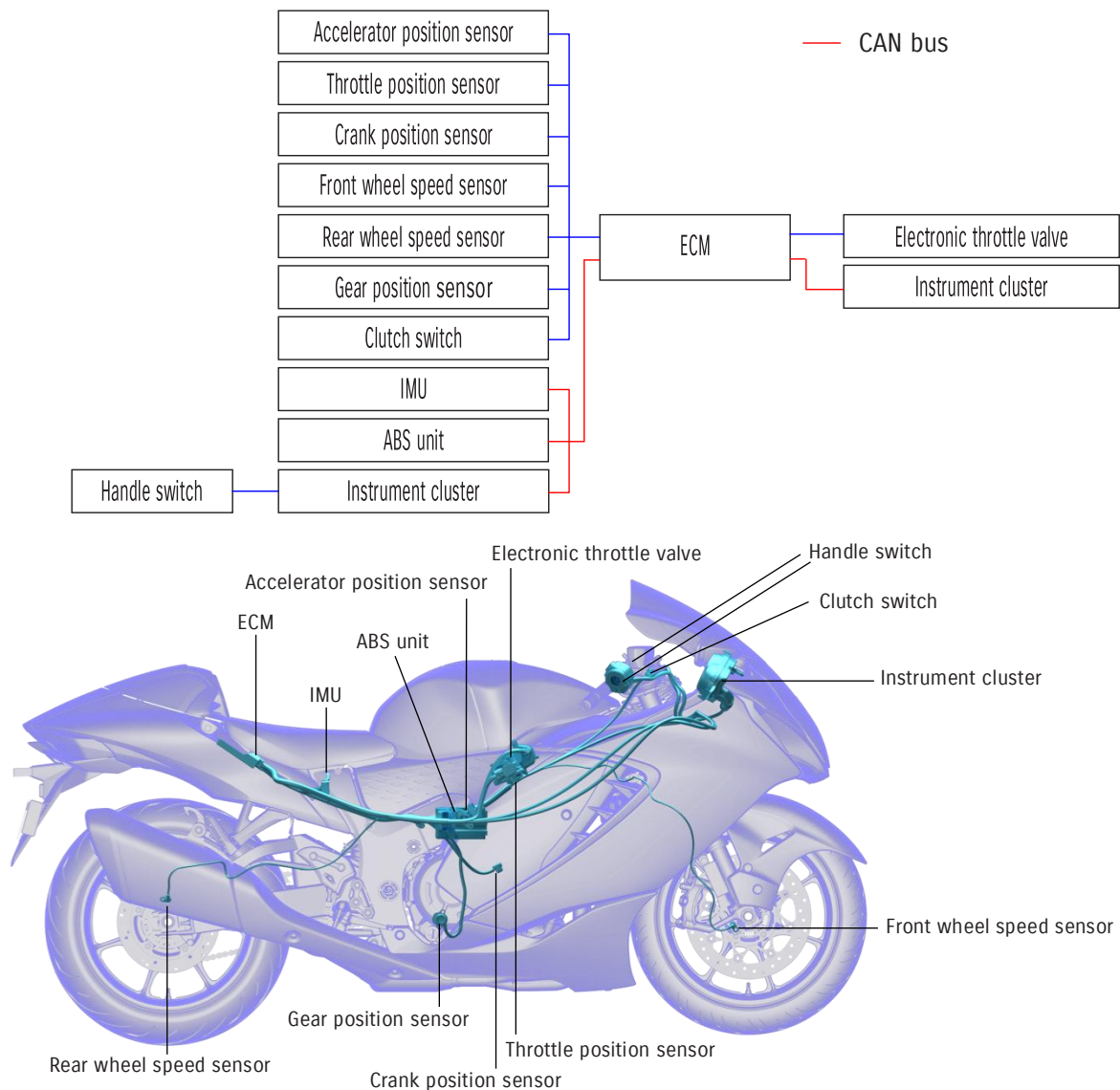

(5) Control over engine operations

Bi-directional Quick Shift System (QS) **NEW**

Allows the rider to shift up or down more quickly and easily, without operating the clutch or throttle. Two modes are offered, with Mode 1 reacting more quickly to replicate racing-style response and Mode 2 offering a lighter touch.

To ensure smooth shift action with Quick Shift on, the ECM retards ignition when accelerating or maintaining steady speed and opens the throttle valve when decelerating, which in turn automatically blip the throttle when downshifting. Performance of the new assist & slipper clutch ensures even smoother up and down shifts.

Overview diagram

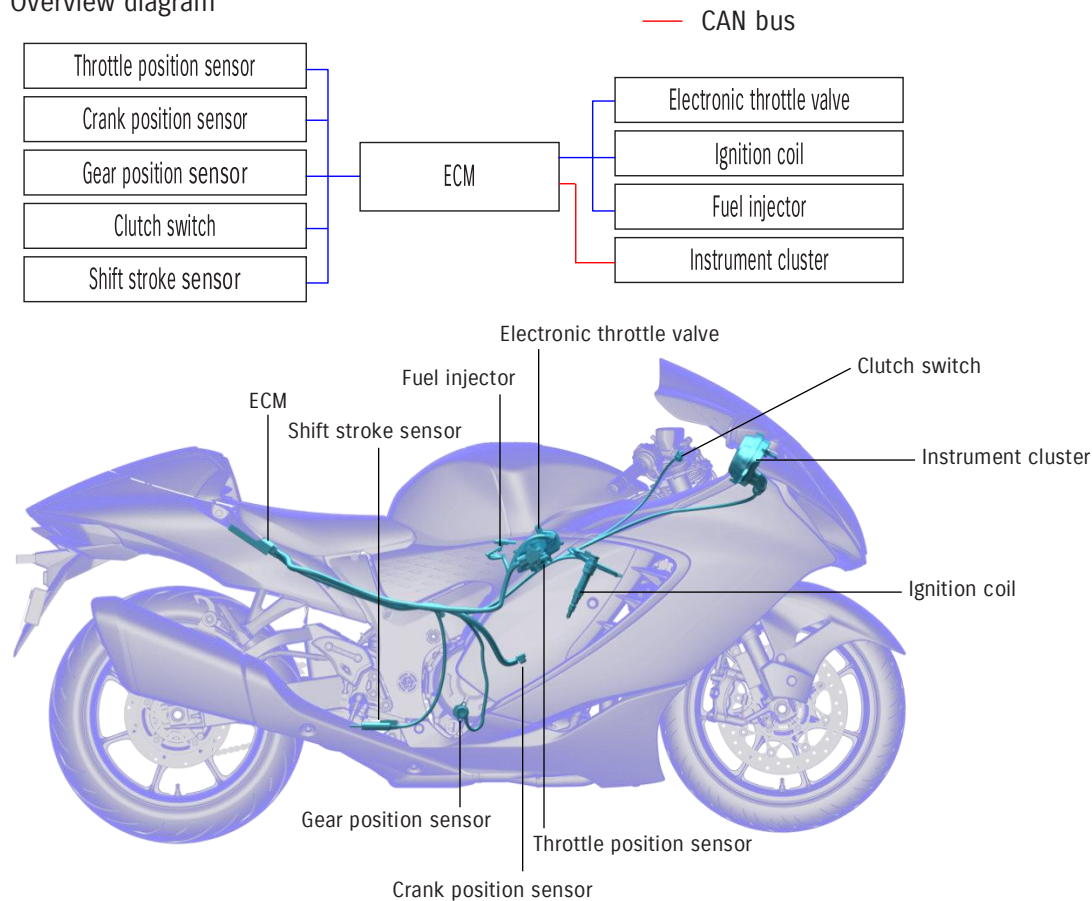

Suzuki Easy Start System **NEW**

Lets the rider start the motorcycle with one quick press of the starter button. There is no need to pull in the clutch lever when the transmission is in neutral, and the starter motor automatically disengages the instant the engine fires up.

Low RPM Assist **NEW**

Seamlessly boosts engine speed when launching from a standing start or riding at low speeds to suppress engine stalls and help ensure better control and operation in stop-and-go traffic.

(6) Control over braking

Combined Brake System **NEW**

Simply operating the front brake lever provides braking power to the both front and rear brakes. This can support more confident braking.

Motion Track Brake System **NEW**

This system enhances control by allowing ABS activation not only when travelling in a straight line, but also when the bike is leaning into a corner. Monitoring input from the front and rear wheel speed sensors as well as vehicle posture data from the IMU, the ABS unit's ECU determines when intervention is called for. When it is, the ABS unit's hydraulic unit controls brake pressure in response to the data being received from the front and rear wheel speed sensors and the IMU. By reducing the impact of sudden braking force, the bike is less likely to try to push itself upright or lose traction, instead maintaining its radius and lean angle to better trace the rider's intended line through the corner. Even if the rider panics and brakes heavily in a corner, the system assists in maintaining stability while stopping or slowing the machine.

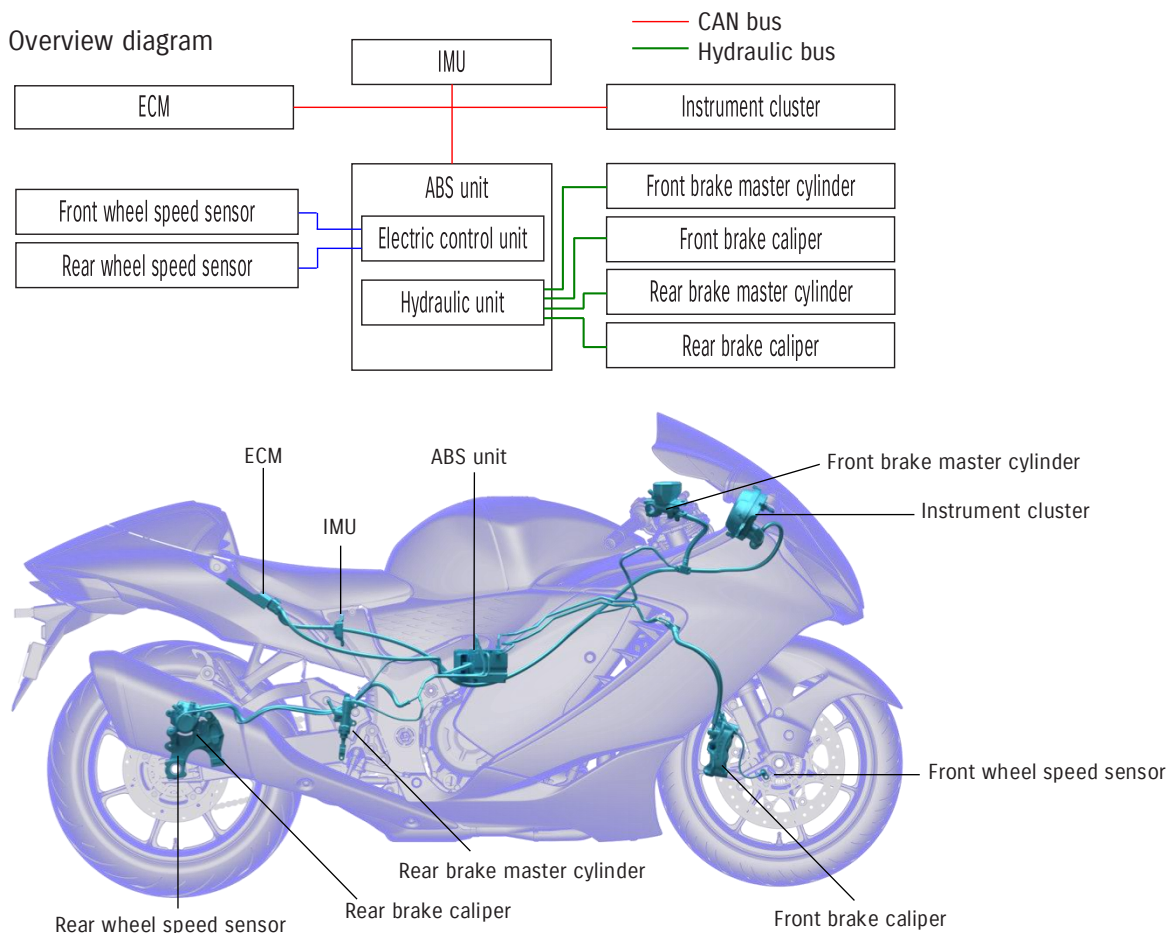

Note: ABS is not designed to shorten the braking distance. Please always ride at a safe speed for road and weather conditions, including while cornering.

Slope Dependent Control System **NEW**

Prevents rear wheel lift when braking while travelling downhill. The ABS unit uses input from the IMU to monitor the bike's posture and, when the rider applies the brakes, the ABS's hydraulic unit controls brake pressure to deliver the optimum setting to match the angle of inclination. Because it continually adjusts the amount of rear lift control to match the current angle of the slope, the system helps provide more stable braking.

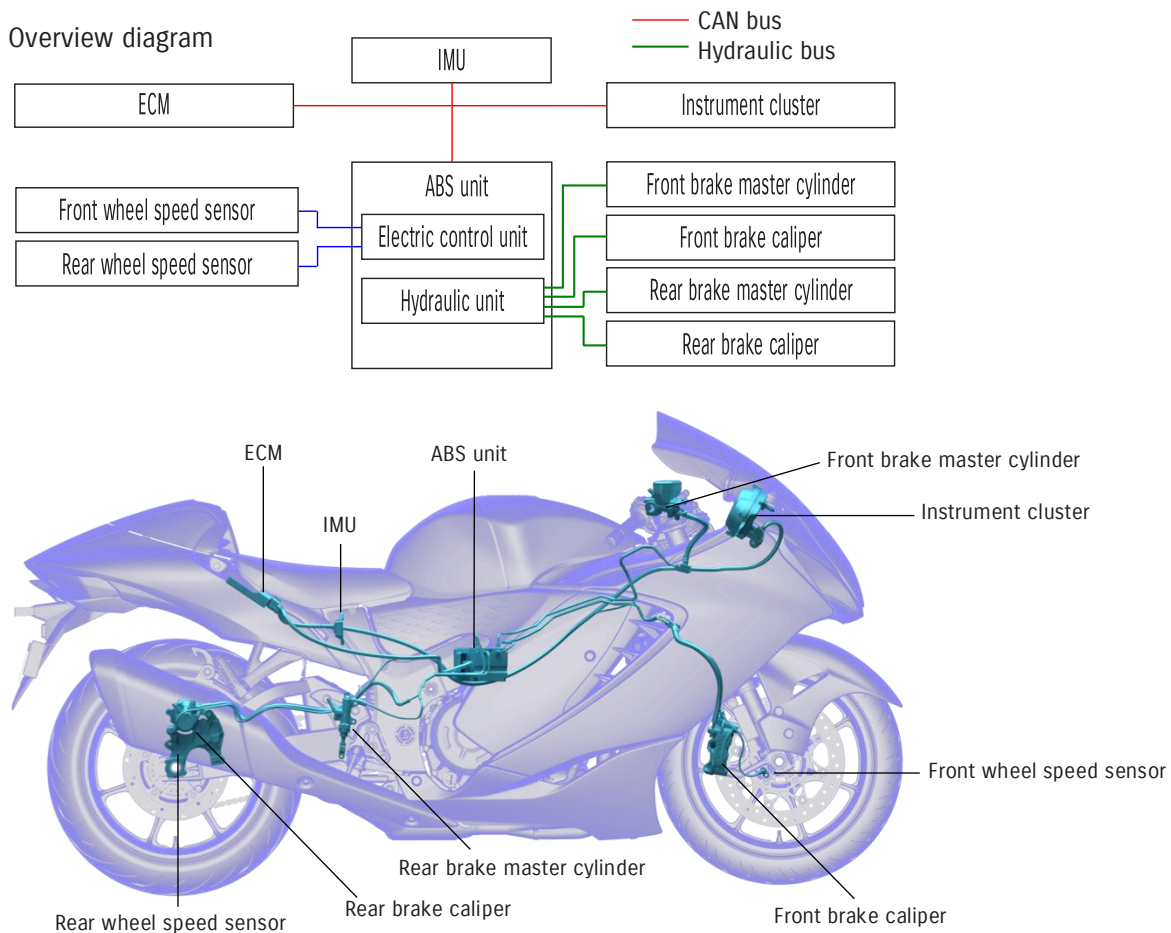

Hill Hold Control System **NEW**

When turned on, the system uses input from the IMU, which constantly monitors the bike's posture, to automatically engage the rear brake for 30 seconds once the motorcycle comes to a stop facing uphill on an incline, even if the rider releases the brake lever or pedal. This helps ensure a smoother restart free of worries that the bike will roll backward. Hill Hold Control can be disengaged either by quickly squeezing the front brake lever twice or when the rider starts accelerating to pull away from a standing start. An "H" mark lights on the instrument cluster when the system is engaged, and flashes when the system is disengaged.

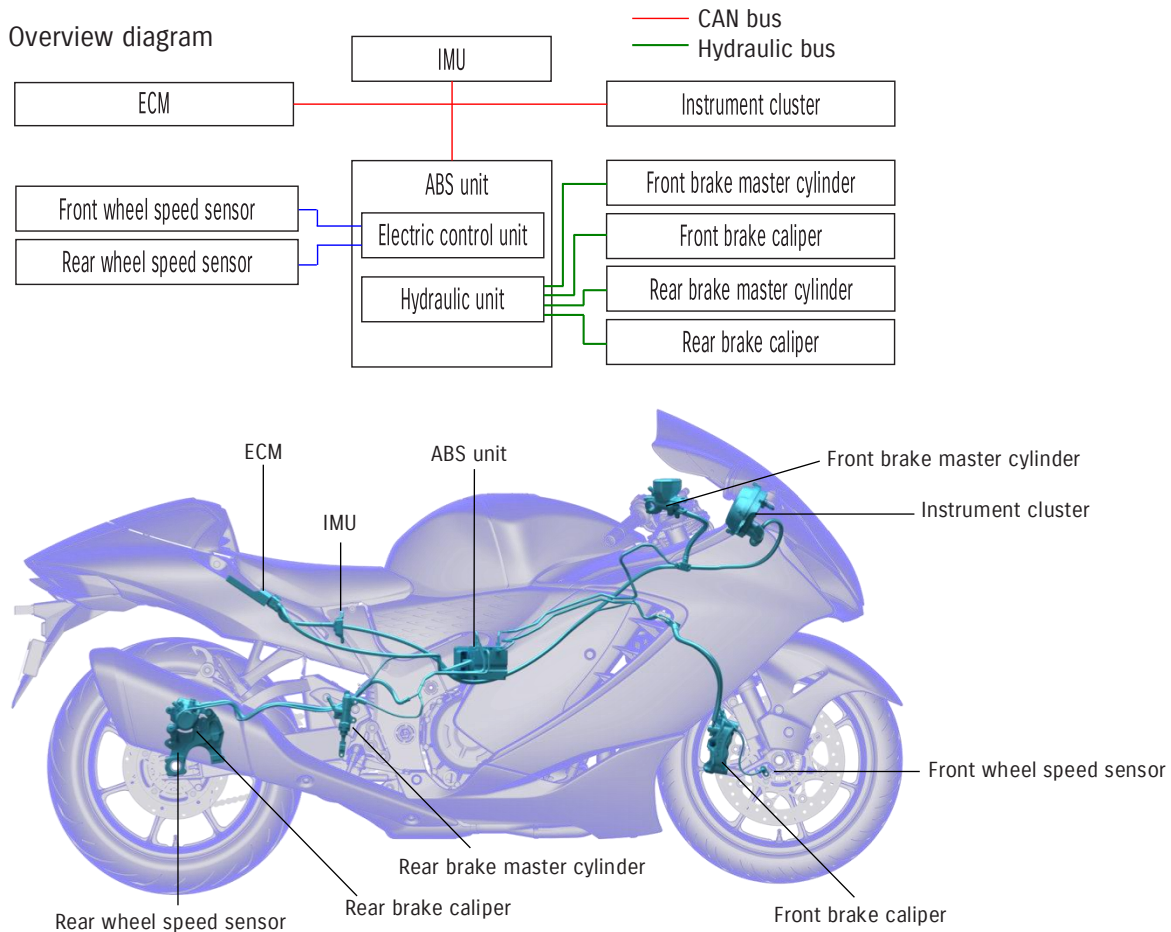

Emergency Stop Signal **NEW**

Another first on a Suzuki motorcycle, this function rapidly flashes the front and rear turn signals to alert following vehicles if the rider brakes suddenly at speeds of 55 km/h or higher.

Note: Emergency Stop Signal is not available on North American, Indian or Canadian specification units

Supporting technologies

Inertial Measurement Unit (IMU) **NEW**

One supporting technology that helps realize the advanced features above is a new 6-axis IMU supplied by Bosch. Combining accelerometers and gyroscopes in a single compact package, the IMU measures angular rate and acceleration to constantly monitor pitch, roll, and yaw movement. The new Motion Track Traction Control, Anti-lift Control, Active Speed Limiter, Cruise Control, Motion Track Brake, Slope Dependent Control and Hill Hold Control systems employ data provided by the IMU.

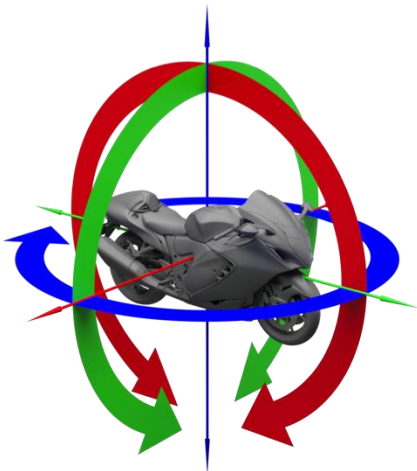

IMU / 6-axis, pitch, roll, yaw



IMU

Controller Area Network (CAN bus) **NEW**

The Hayabusa adopts a robust CAN bus that enables its various sensors and microcontrollers to communicate with each other. The capabilities it brings to the table are what make it possible to include advanced systems such as SDMS- α , Motion Track Traction Control System, Anti-lift Control System, Cruise Control System, Active Speed Limiter, Slope Dependent Control and Hill Hold Control System.

Engine Control Module (ECM) **NEW**

A new dual-core 32-bit ECM provides state-of-the-art engine management that contributes to the operation and optimization of several critical systems.



ECM

ABS unit **NEW**

The Hayabusa is equipped with the latest compact Antilock Brake System (ABS) unit from Bosch. Working in conjunction with the new IMU, the ABS unit realizes features such as the Motion Track Brake System, Slope Dependent Control System and Hill Hold Control System.



ABS unit

Introduction

The following design targets drove chassis development for the new Hayabusa.

1. Provide a more stable ride with nimbler handling.
2. Optimize aerodynamic performance and wind protection.
3. Improve braking performance and efficiency.

The Hayabusa's chassis is designed to empower the rider with sure footing, nimble handling and predictable control that inspires confidence and enhances the riding experience. It delivers a smooth and comfortable ride that absorbs everything the road surface throws at it and responds faithfully to the rider's will. It effectively transfers the power of its legendary powerplant to the pavement while fully leveraging its intelligent control systems to run and brake effectively, whether riding straight or leaning through corners.



Twin-spar aluminum frame and swingarm

The Hayabusa's tried-and-true twin-spar aluminum frame and swingarm incorporate aluminum castings along with extruded aluminum sections that lend the right amount of suppleness and strength to its overall rigid alloy frame structure. While more costly and demanding to fabricate, extruded aluminum sections pay off in achieving the overall balance required by a machine that delivers ultimate performance and reaches a top speed of 299km/h. This is why extruded aluminum can also be found used on a number of supercar frames, and why the Hayabusa leverages its benefits.

A new seat rail designed in conjunction with the bike's styling changes features straighter pipe sections and reduces weight by 700 grams.



Frame

Suspension optimized for a more stable, nimble ride **UPDATE**

Front and rear suspension settings are optimized to eliminate any hint of oversteer at lower speeds and achieve a stable ride with neutral feel at all speeds. These combine with the Hayabusa's low center of gravity, long wheelbase and new tires to realize nimble handling along with reassuring straight-line stability at highway speeds.

Up front is an updated version of the Hayabusa's fully adjustable KYB inverted forks with 43mm outer diameter DLC-coated inner tubes. The internal structure has been revised to further improve the forks' ability to absorb the road surface and ensure a smoother, more stable ride with optimum grip. In similar fashion, the internal structure of the fully adjustable KYB rear shock absorber was also revised to help optimize comfort and straight-line stability.



Front suspension



Rear shock absorber

Aerodynamic bodywork **UPDATE**

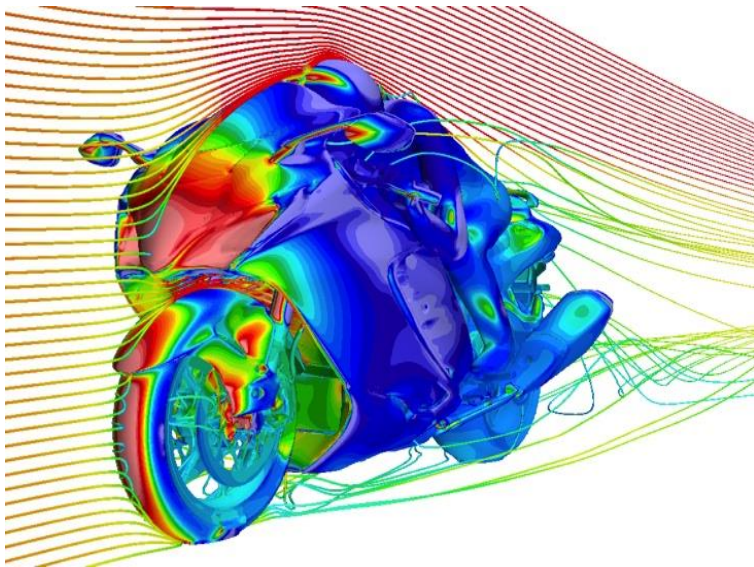
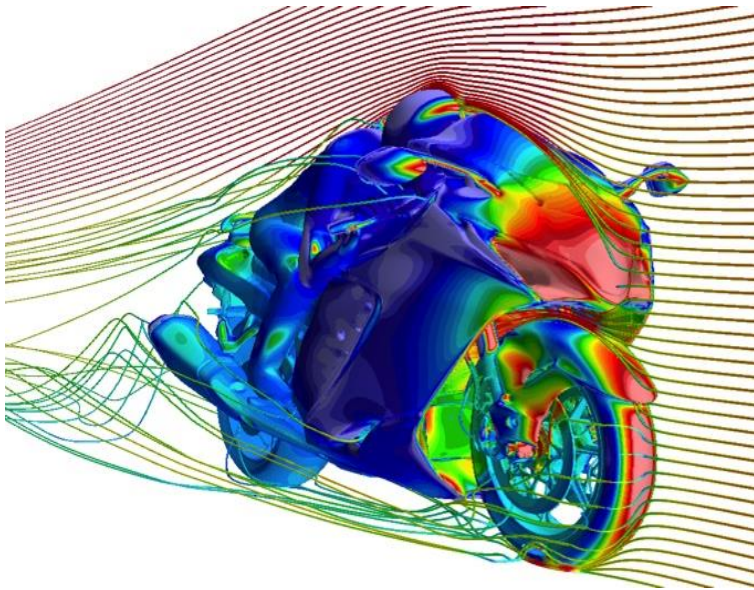

Pressure distribution / velocity distribution chart

Aerodynamic performance is critically important on a motorcycle capable of reaching top speeds nearing 300km/h. And ultimate performance is what the Hayabusa is all about. Suzuki's engineers took full advantage of extensive wind tunnel testing, the latest CAE analytical tools and know-how accumulated over the years to achieve one of the best drag coefficients found on any street legal motorcycle. Although priority went to styling refinements, the new Hayabusa realizes a drag area (CdA) on par with the previous generation. This continues to earn it a podium spot as one of the top three street-legal bikes in terms of CdA, despite its relatively large frontal area. So, while bringing a sharper new look of modern styling and class to the new generation, the Hayabusa's body design remains true to the wind-cutting nature of its predecessors and even modestly improves on lift and stability at high speed.

Attention to detail extends to design elements that enhance aerodynamic performance while also offering wind protection to improve comfort and reduce riding fatigue. For example, the V-shaped chrome-plated moldings in front of the air ducts on the side cowlings create a styling accent flowing from the engine to the mufflers that visually expresses the immense amount of power emanating from the engine, but are also functional parts that draw wind away from the rider's legs. Likewise, the black plastic accent pieces that extend from the sides of the upper cowl near the handlebars protect the rider's elbows and knuckles. It also includes the introduction of a sharp new mirror design and holes added to the clutch and brake levers. These holes look great and contribute to aerodynamic performance, while also reducing the chance of wind pressure pushing against the brake lever.

A new windscreen that offers added wind protection is also available as a genuine accessory. It is 38mm taller than the standard equipment part.



New brake lever



New mirror



New windscreen

Brembo Stylema® front brake calipers paired with 320mm outer diameter discs NEW

The Hayabusa adopts Brembo's latest Stylema® front brake calipers. Featuring a lighter, more compact and carefully sculpted design, these new calipers increase airflow around the brake pads to cool more quickly and deliver immediate response. The diameter of the front discs is increased from 310mm to 320mm and a new hole pattern adopted to further help optimize cooling efficiency.



New brake calipers

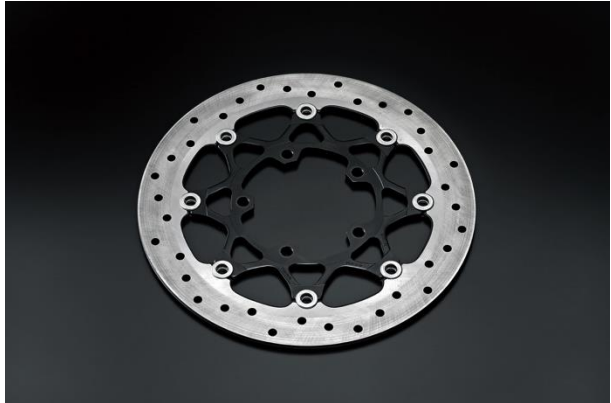

New front brake disc

New tires offer better grip, handling and durability **NEW**

Suzuki worked closely with Bridgestone in developing the new BATTLEAX HYPERSPORT S22 tires especially to meet the needs of the Hayabusa for long years. Throughout this ongoing iterative process, Bridgestone responded to the sharp but constructive criticism tabled by Suzuki's test riders time and time again. The result is a greatly evolved level of performance and a tire that realizes significant advances. Featuring a new compound and construction, these tires improve grip on dry roads, performance in wet conditions, and provide greater all-round agility. The marked difference they demonstrate in straight-line stability and cornering grip offers every rider a more exciting and confidence-building experience.

BATTLEAX HYPERSPORT S22



New tires



New front tire



New rear tire

Attention to detail throughout

- The lighter, more compact muffler design reduces weight in the rear by 2,054 grams and combines with the 700-gram lighter new seat rail design to help move mass forward to achieve 50:50 front/rear weight distribution. **UPDATE**
- The coloring the new mufflers take on over time is directly affected by the way the bike is driven. This makes it possible for each rider to add a unique personal touch to his or her Hayabusa. **UPDATE**



New mufflers

- New 7-spoke wheel design improves grip feel as well as appearance. **NEW**
- The floating handlebar mount helps minimize vibration, while changes to the design realize a more attractive look with luxurious appeal. **UPDATE**



New handlebar

- Mounting the handlebars 12mm closer to the rider vastly improves comfort and reduces fatigue, particularly when touring or taking other long rides. It also enhances handling when enjoying a sporty ride by giving the rider better feedback on how well the front tire is gripping the road, by better supporting the rider's posture to improve stability when braking, and by offering the rider greater freedom in movement to control cornering. **UPDATE**

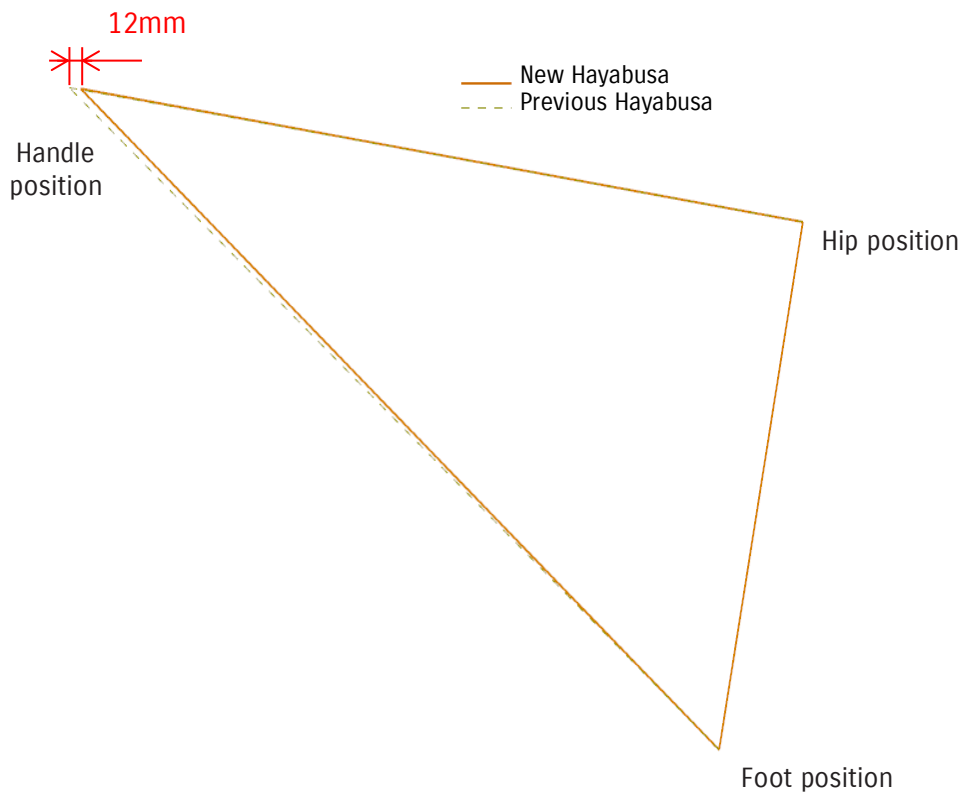

Riding position comparison

- The grab bar is visually appealing and features an ergonomic design to the shape that makes it easier to hold onto. **UPDATE**



New grab bar

Design concept:**“The Refined Beast”**

The Hayabusa’s unique styling and striking aerodynamic silhouette have made it instantly recognizable since the first generation launched in 1999. Low, long and wide, it’s a magnificent beast whose stance screams of power, performance, poise and keen perceptive abilities. Just like the Japanese peregrine falcon from which it takes its name.

The new generation faithfully inherits this DNA while bringing it firmly into the present. And the future. The fresh new look Suzuki’s design team worked so hard to create introduces sharper lines with a tough, modern look that speaks of refinement and ultimate performance. To this, they applied a tasteful blend of textures, colors and design elements intended to lend visual expression to immeasurable potential offered by the power of the engine and controllability provided by latest electronic control systems. The overall result is a look of higher quality and greater luxury fused with the daunting image of a fierce bird of prey.



Image sketch

Aggressive stance **NEW**

Great effort was devoted to designing thinner, more compact mufflers that draw a straight line sweeping up from the exhaust pipes. This not only makes the rear look lighter and creates a mass-forward image, it also combines with the sharp new upswept tail design to further emphasize the Hayabusa's aggressive stance and eagerness to perform. Adding cleanliness and flair to the bold new look of the tail are sharp, wide new LED rear combination lights.

Modern look with a stronger sense of luxury **NEW**

From every angle and in every detail, the design features straighter, sharper lines. These create a tauter impression of modern appeal that is sure to turn heads. The added lines and intricately tucked bodywork on all the panels, from the cowling and fuel tank through to the tail section, also realize a look of higher quality and greater luxury. The sharp, angular look of the new mirror design is another example.

A fresh face **NEW**

The Hayabusa's vertically stacked headlight continues to feature intentionally large, bold styling. Even so, the design for the new generation assumes a tighter, more angular look that nests neatly between the large Suzuki Ram Air Direct (SRAD) intake ducts and melds seamlessly with the narrower lines of the windscreen's lower edge. Black parts incorporated inside its housing add a striking new touch and make the assembly less conspicuous. Flanking the air intakes are new position lights with integrated turn signals. They form a single clean vertical line that flows back along the cowling and does away with the protrusions the turn signals formed on the previous generation.

Color as a visual expression of potential **NEW**

The color concept aims to heighten the visual expression of hidden potential. For example, the splashes of the two-tone color scheme's secondary color. These represent the flow of air that slides smoothly along the Hayabusa's aerodynamic form and around the rider.

Another example is the side cowlings incorporate chrome-plated V-shaped moldings oriented like a forward-facing arrowhead to add an accent that flows from the top of the engine down to the mufflers. This conveys the ability of its large-displacement 1,340cm³ engine to deliver the ultimate in power and top speed performance.



Image sketch

A trio of themed two-tone body colors **NEW**

Glass Sparkle Black / Candy Burnt Gold: Uses splashes of gold to create impact and add a touch of luxury. The contrast of gold on black is inspired by fine Japanese lacquer ware.

Metallic Matte Sword Silver / Candy Daring Red: Deftly leverages splashes of red to create a visual expression of hidden power. The silver represents a futuristic image and expresses intelligence.

Pearl Brilliant White / Metallic Matte Stellar Blue: White with blue as the accent color represents the spirit of Suzuki.

Hayabusa logos **NEW**

The English (“Hayabusa”) and Japanese (“隼”) logo designs were updated to more strongly evoke an image of speed and sophistication. Both logos adopt sharper, more highly stylized strokes, and the English logo features a long cross stroke on the “H” that emphasizes a sense of speed.



New key



New “隼” logo



New “Hayabusa” logo

In addition to the bold character on the side of the cowling, smaller versions of the Japanese logo add highlights on the black shroud over the projector-type high beam headlight, on the front of the single-seat cowl piece (genuine accessory), and even as a start-up animation on the TFT LCD panel. Groupings of V-shaped accents inspired by the peregrine falcon’s hackles (neck feathers) are featured on the black cladding below the fuel tank, in front of the air intakes on the cowling, and on the footpegs.



New “隼” logo in headlight



New V-shaped accents

Instrument Cluster **NEW**

Riders love the outstanding functionality and familiar layout of the Hayabusa's instantly recognizable instrument cluster. Now it benefits from a number of carefully considered touches that give it a modern new look and make it's functional brilliance shine even brighter.

The large analog tachometer and speedometer gain a fresh, more attractive appearance. Features include bigger, bolder numbering that improves readability. Raised scale markings around the periphery of each meter use LED lighting to provide a clearer view and faster recognition, both at midday and at night. Carrying the theme of gold colored accents throughout the cockpit area, the analog fuel and coolant temperature gauges that flank the meters are ringed in gold, as are the SDMS and Active Data display screens on the TFT LCD panel.

One standout new feature is the TFT LCD panel mounted in the center, between the two main meters. It displays either the current SDMS- α systems settings or an Active Data display that shows lean angle (with peak-hold function), front and rear brake pressure, rate of forward/reverse acceleration, and the current accelerator position. The panel also shows clock, gear position, odometer, dual trip meter, ambient temperature, instantaneous fuel consumption, riding range, trip time, average fuel consumption, and voltmeter displays. LEDs located in the corners above and below the LCD include the neutral indicator light, turn-signal indicator lights, high-beam indicator light, low oil pressure warning light, TC (Traction Control) indicator, MIL (Malfunction Indication Lamp), master warning indicator, and ABS indicator. There is also an LED engine coolant temperature indicator light in the upper right corner of the engine coolant temperature gauge and fuel indicator light in the upper left corner of the fuel meter gauge. An ambient light sensor automatically adjusts the instrument cluster's brightness level based on surrounding conditions, but the rider can also opt to make manual adjustments.

An additional feature of the LCD panel is a brief animation of the Hayabusa kanji character that plays when the ignition key is turned on. This playful presentation is pleasing to the eye and heightens anticipation of the ride to come. A second animation featuring the Suzuki logo plays before the display is turned off.



*All lights and indicators are illuminated in the photo for illustrative purposes.



SDMS-a display*



Active data display*

*All lights and indicators are illuminated in the photo for illustrative purposes.

Highly functional and attractive lighting

Multi-LED headlight **NEW**

Both the low beam and projector-type high beam headlights adopt LEDs that provide clear illumination and help make the Hayabusa clearly visible to pedestrians and other traffic at night. The vertically stacked design creates a sharp new look with its large, bold styling and eye-pleasing presence. Attention to achieving a memorable look extends to every detail. The two upper and two lower LEDs for the low-beam are mounted in the corners where they shine across a reflector panel and fill the light assembly with attractive illumination. Fine touches throughout the headlight assembly include the use of black parts that heighten the sharp looks, as well as the inclusion of the Hayabusa kanji character on top of the black cowl above the high beam lamp.



Position lights with integrated turn signals **NEW**

A new design marking a first on a Suzuki motorcycle integrates the LED position lights and turn signals into single assemblies that neatly flank the outer edges of the large SRAD air intakes. An illumination scheme using white lighting for the position light with the turn signals flashing in orange when they are on creates a unique overall effect that heightens the sense of a luxurious riding experience.

Note: Not available on Indian specification units.



New position lights



New turn signals

LED rear combination lights **NEW**

The bold new LED taillight and rear turn signal design creates a single wide, sharp accent running horizontally across the bottom of the tail section. Each of the left and right combination lamps houses the tail/brake light and turn signals, with a clear lens over the taillight and a clear smoke lens over the turn signal portion.



Ergonomic handlebar switch design **NEW**

The handlebar switches are laid out to maximize operating ease and efficiency. The mode/set switch on the left handlebar controls various Suzuki Intelligent Ride System (S.I.R.S.) settings and adjustments, including for cruise control. A single button added to the right handlebar switch engages cruise control.



New left handlebar switch



New right handlebar switch

8. GENUINE ACCESSORIES

Hayabusa

Suzuki's lineup of genuine accessories allows each rider to customize their Hayabusa to best express their personal tastes.



1 Touring screen



2 Single seat cowling



3 Color seat



4 Grip heater



5 Chrome plated filler cap



6 Fuel tank bag with ring fixation (Large)

8. GENUINE ACCESSORIES

Hayabusa



7 Fuel tank bag with ring fixation (Small)



8 Wheel rim decal with SUZUKI logo



9 Tire valve cap



10 Aluminum oil filler cap



11 Front axle slider



12 Aluminum chain adjuster



13 Billet brake lever



14 Billet clutch lever



15 Carbon look mirror cover

8. GENUINE ACCESSORIES

Hayabusa



16 Luggage hook



17 Hayabusa fuel tank pad



18 Hayabusa rim decal



19 Fuel tank protection sticker



20 Hayabusa slip-on muffler by Akrapovič

Note: SUZUKI MOTOR CORPORATION reserves the right to add any improvement to change the design or to discontinue any Suzuki Genuine Accessories at any time without notice. Some Suzuki Genuine Accessories might not be compatible with local standards or statutory requirements. Please check with your local AUTHORIZED SUZUKI DEALER for details at the time of ordering.



B5L (Glass Sparkle Black / Candy Burnt Gold)



B5M (Metallic Mat Sword Silver / Candy Daring Red)



B5N (Pearl Brilliant White / Metallic Mat Stellar Blue)

The image includes an optional accessory.

10. SPECIFICATIONS

Hayabusa

Overall Length	2,180 mm (85.8 in.)	
Overall width	735 mm (28.9 in.)	
Overall height	1,165 mm (45.9 in.)	
Wheelbase	1,480 mm (58.3 in.)	
Ground clearance	125 mm (4.9 in.)	
Seat height	800 mm (31.5 in.)	
Curb weight	264 kg (582 lbs.)	
Engine type	Four-stroke, liquid-cooled, DOHC, in-line four	
Bore x stroke	81.0 mm x 65.0 mm (3.189 in. x 2.559 in.)	
Engine displacement	1,340 cm ³ (81.8 cu. in.)	
Compression ratio	12.5:1	
Fuel system	Fuel injection	
Starter system	Electric	
Lubrication system	Wet sump	
Transmission	6-speed constant mesh	
Suspension	Front	Inverted telescopic, coil spring, oil damped
	Rear	Link type, coil spring, oil damped
Rake / trail	23° 00' / 90 mm (3.54 in.)	
Brakes	Front	Brembo Stylema®, 4-piston, twin disc, ABS-equipped
	Rear	Nissin, 1-piston, single disc, ABS-equipped
Tires	Front	120/70ZR17M/C (58W), tubeless
	Rear	190/50ZR17M/C (73W), tubeless
Ignition system	Electronic ignition (transistorized)	
Fuel tank capacity	20.0 L (5.3 US gal)	